

Some Instructions for
the Sharing of Private Property

TABLE OF CONTENTS

	Page
Introduction	iv
Basic Lock Picking	1
The Concepts Behind Lock Picking	3
Picking Procedure	7
Tool Design	9
Most Common Picking Techniques	19
The Lockpicking Process	21
Conclusions	47

INTRODUCTION

There has been much opinion and little fact written on the subject of lock picking. It will be my purpose to clarify the facts about this process and at the same time train you in proper procedure so that before you leave this class today, you will at least have picked one lock. Please note that to become truly proficient you must devote much time and patience in the future.

In this volume we will discuss not only the fundamental theories of lock picking but proper terminology, the importance of tool design (using the right tool for the right job), the effects of tolerances, and finally the techniques most commonly used by locksmiths to successfully pick the vast majority of standard pin and wafer tumbler locks.

CHAPTER

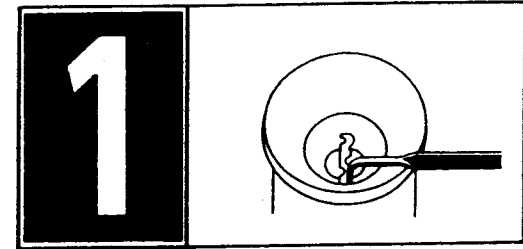

BASIC LOCK PICKING

First of all, lock picking must be divided into two categories which are commonly confused:

The first category is picking (the act of carefully manipulating one pin at a time for the expressed purpose of duplicating the action of the proper cut key in a given cylinder, by something other than the proper cut key itself).

The second category is raking (the less specific act of taking a raking instrument for the expressed purpose of gliding the tool across tumblers of approximately the same depth in a general yet sequential fashion).

Either of these techniques is intended to be a method of convenience for opening locks in emergency type situations. Obviously, the method for making keys referred to as impressioning would be far more desirable since both processes take about the same time and only one yields both an open lock and a working key. However, there are times when picking is the most logical method to use (i.e. when someone is locked out of a house or car and the keys are inside). Both methods are predicated on their efficiency and, should either take an undue amount of time, it is questionable how worthwhile they are when a method such as drilling is so quick and sure, though more expensive.

In order to understand how to compromise a lock there are certain steps which are essential to laying a proper foundation. They are: A thorough working knowledge of the lock mechanism, how it functions, and the ability to recognize these factors so that you are able to overcome them.

CHAPTER

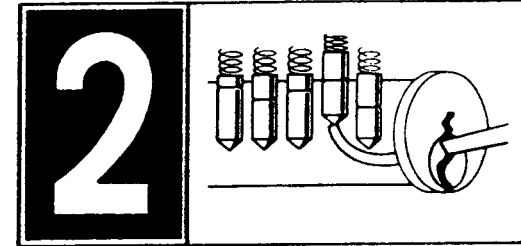

THE CONCEPTS BEHIND LOCK PICKING

Have you ever thought, “Just what is it that actually allows us to pick a lock?” It is the inability of the manufacturer of any product to machine parts to an almost flawless level of tolerance. Even if they could reasonably approach their goals, the expense alone would be astronomical.

Therefore, we, as locksmiths, are able to pick a lock, so to speak, due to the reality of this situation. To see specifically what is involved, we must look at a typical cylinder.

FIGURE 1

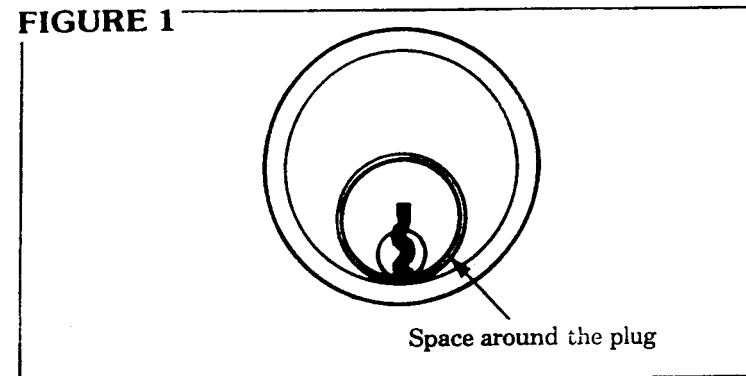

The tolerance inadequacies to which I refer can be categorized for easy reference. The first is the difference between the plug and the shell. An acceptable amount of

difference is approximately .005 or about .0025 all around the plug (see Figure 1).

The process by which the keyway is "cut" into the plug is called broaching. This process is easily observed when

FIGURE 2

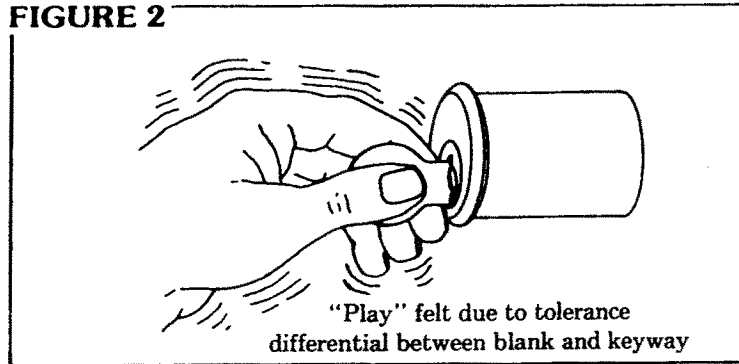

a blank or cut key is inserted in the keyway and "play" is felt due to a significant tolerance differential.

Probably the most significant problem of this sort is the drilling of the chambers. This takes three forms: Plug diameter differential (Fig. 3), off-center chambers (Fig. 4),

FIGURE 3

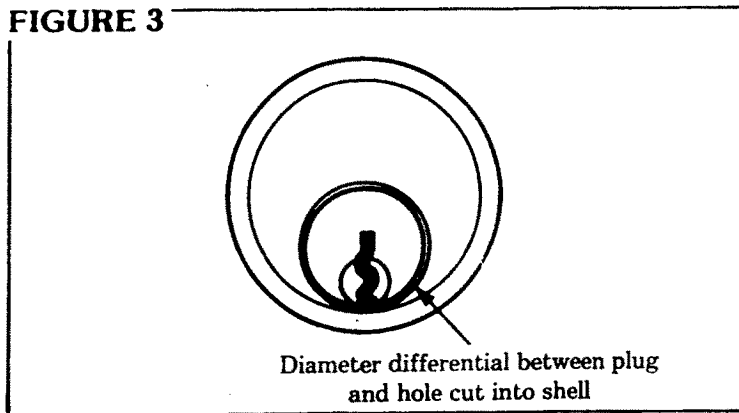

and concentricity (Fig. 5). This is caused by the cost effective but necessarily imperfect process used to manufacture these cylinders, namely gang drilling—a

FIGURE 4

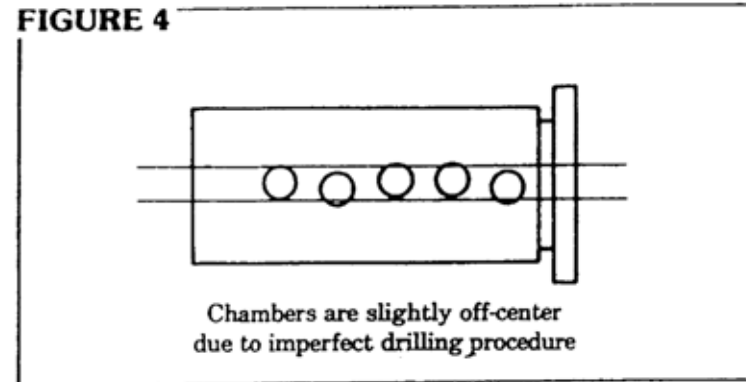

process by which you drill all the chambers at once—and sequential drilling where you drill one chamber after the other. (See illustrations.) In either case, both methods are imperfect because the drill bit itself changes a microscopic amount each time it is used to

FIGURE 5

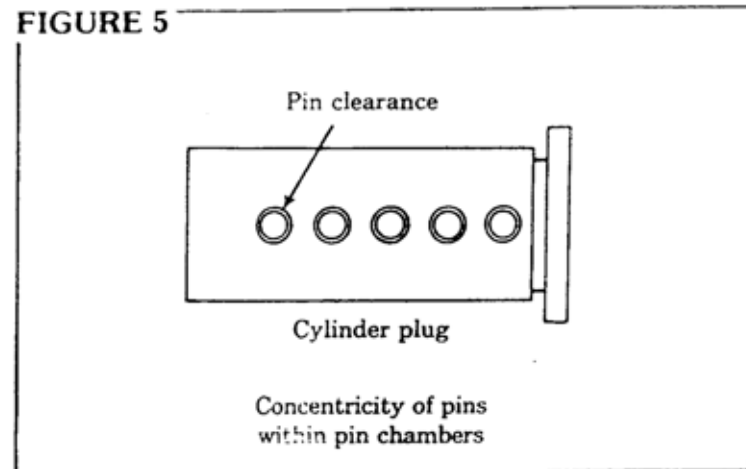

drill a chamber. It is no surprise then, that after a hundred or a thousand holes the diameter and the centering functions based on its original diameter are no longer accurate. However, in deference to the manufacturer, he could not possibly stay in business and change the bit for each hole or set of holes. We are therefore left

with a necessary evil, but one which we can use to great advantage.

When turning tension is applied to the core (without the proper key inserted) again tolerance plays a large role in the next operation . . . Not all of the pins will bind at the same time. Locate those pins, lift them to the correct position (shear line). Follow by doing the same to the next pins to reach the cylinder housing. The only objects which keep the lock from opening are the pins.

CHAPTER

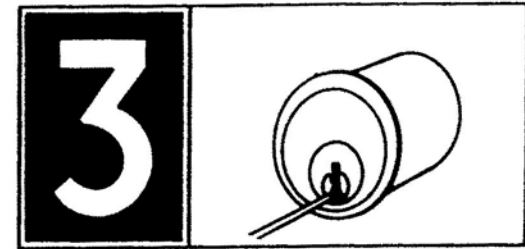

PICKING PROCEDURE

In order to have your best chance to pick a given cylinder, you must not only be aware of the information that we have provided, but be able to properly utilize it. First, ascertain whether or not the cylinder can be picked. Does it operate? Can you manipulate each individual group of pins within each pin chamber? If you can, then by all means proceed with the picking and/or raking

FIGURE 6

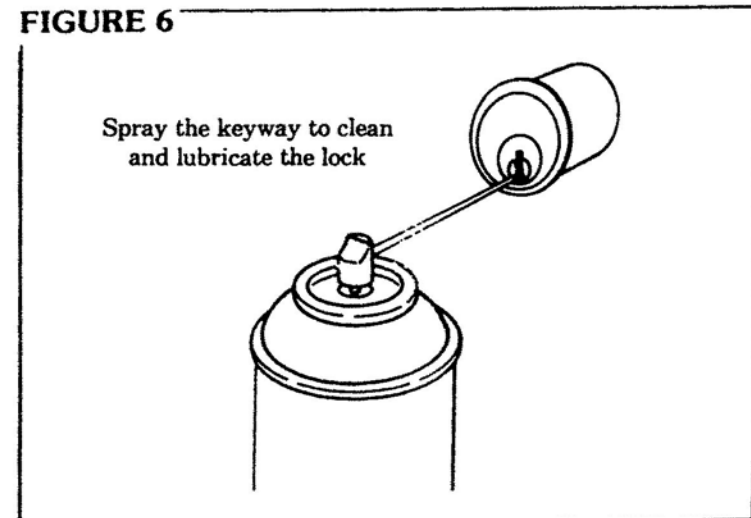

process. If not, there is another alternative if you still intend to pick the lock. This problem is more common than you might imagine. Having set your mind upon

picking the cylinder, but faced with the problem of “frozen” pins in one or more chambers, the best strategy is to clean and lubricate the lock. This can be accomplished several ways. The preferred methods are shown in figure 6 and figure 7.

FIGURE 7

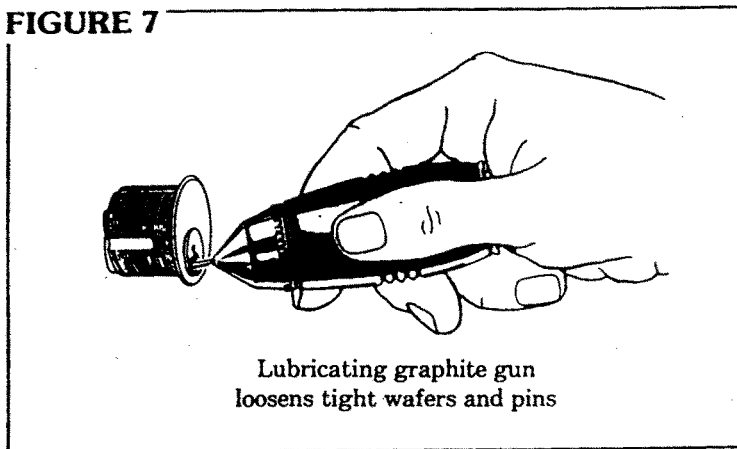

NOTE: After the application of any solvent or lubricant, impressioning will become difficult, if not impossible.

CHAPTER

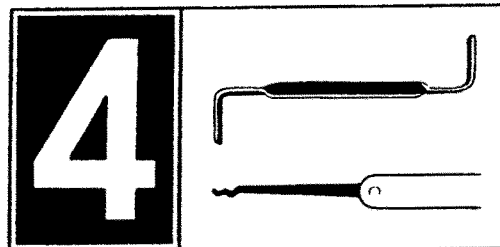

TOOL DESIGN

Tool design is a direct result of the function it will be required to perform, and falls into one of three major categories: The hook tool, used when the adjacent bottom pin lengths are significantly different (i.e., 72618). This tool is advantageous for this type of situation, as it allows you to get behind the larger pins in order to properly reach the smaller ones and manipulate them open.

The diamond pick, which is advantageous due to its design in the manipulation of wafer tumblers, which are more fragile and spaced much closer together.

FIGURE 8

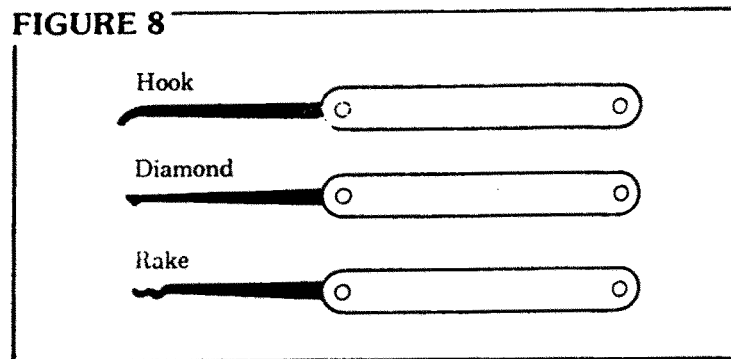

The rake is intended to do just what its name suggests, and is ideal for those situations where all the tumblers are approximately the same size or gradually rise and fall (i.e., 34454, 34565).

The tools required for raking are the rake, the diamond or the ball pick and a tension tool. In this course, I will refer to all raking and picking tools as picks.

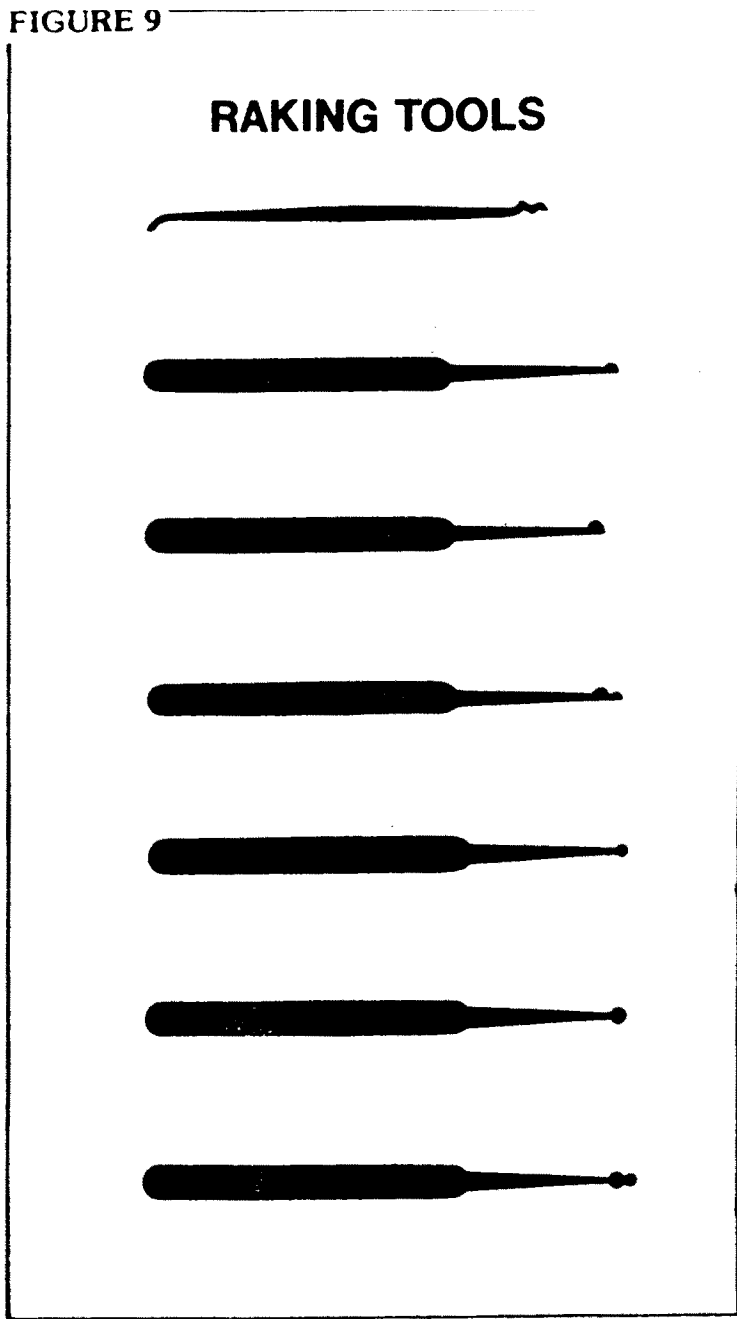
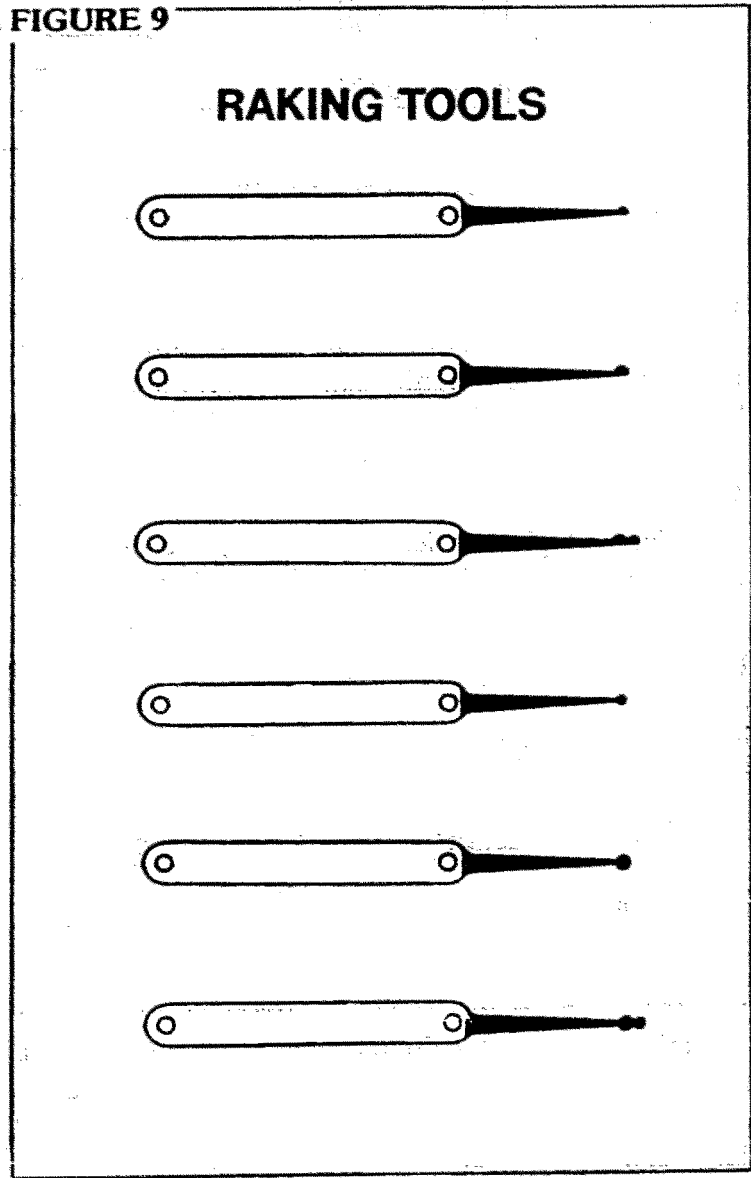

FIGURE 10

RAKING TOOLS

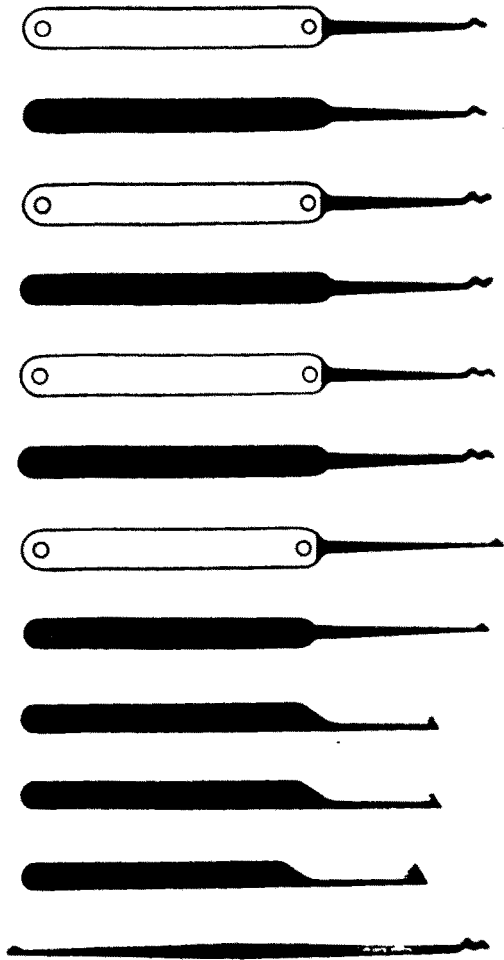
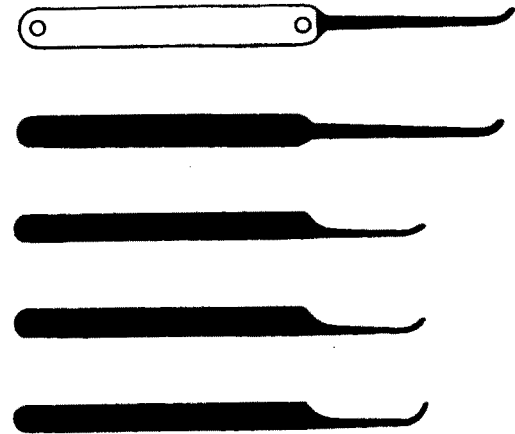
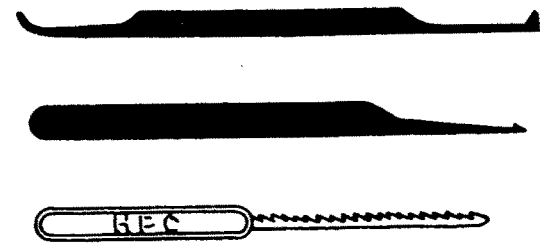

FIGURE 10

PICKING TOOLS



KEY EXTRACTORS



FEELER



Other individual styles of picks are usually just a modification of one of these groups.

FIGURE 11

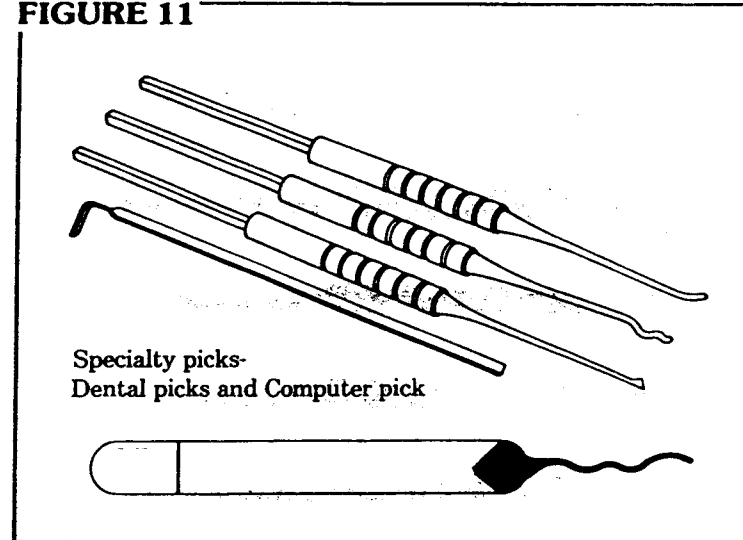

The other tool used in the act of picking is the tension wrench, or more properly, the turning tool. This tool is as or more important than the pick itself but is often overlooked. Too much pressure has defeated more would-be pickers than the wrong type of pick. The main thing to remember is to use only the lightest amount of pressure necessary to turn the lock. Any more, and you bind the pins so tightly that you make them work against you instead of for you.

Turning tools come in basically 6 groups: light, medium, and heavy duty material and narrow, medium, and wide widths to suit any type of lockpicking situation.

Before you use your tension tool, try raking with the pick a few times. While inserting the pick all the way in the keyway with the tip in contact with the pins, remove the pick with a quick motion keeping an upward

pressure on the pins. Repeat this operation again, in slowly and out with a slight snap. Now you are ready to use the tension tool. There are many tension tools to choose from. To start with, I suggest you choose a tool of medium weight and length.

FIGURE 12

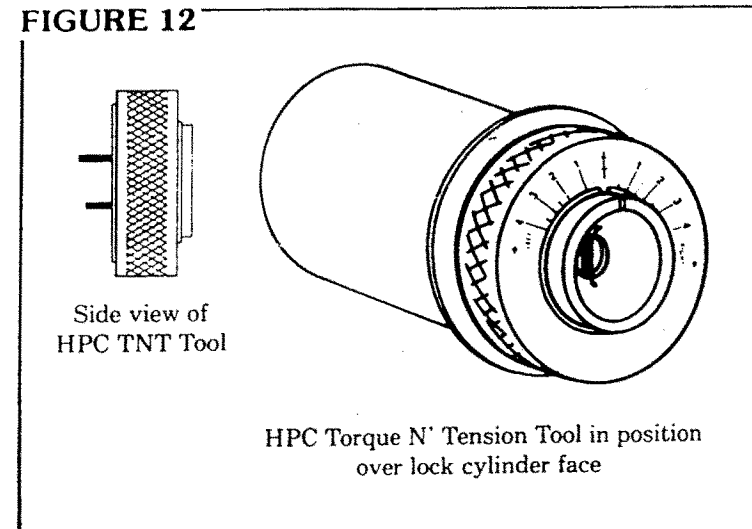

See diagram of other tension tools on the following page

FIGURE 13

TENSION TOOLS

LIGHT WEIGHT

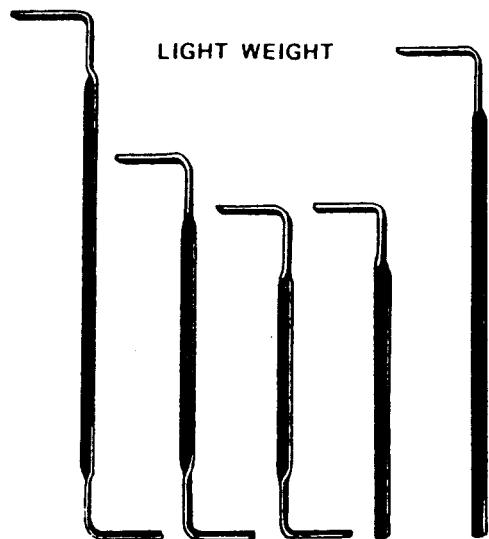

MEDIUM WEIGHT

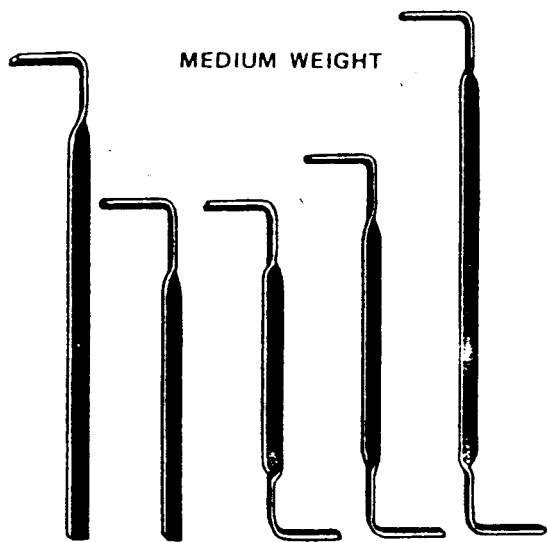
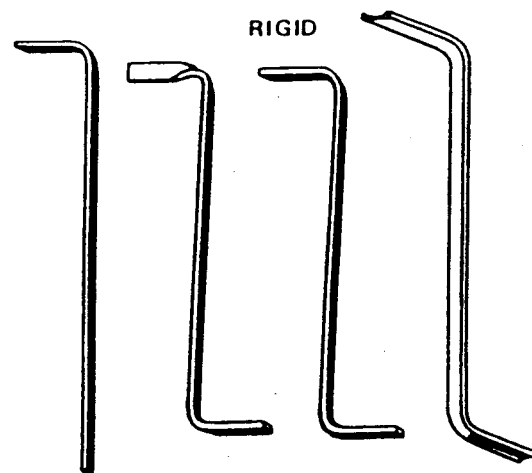

FIGURE 13

TENSION TOOLS

RIGID



DOUBLE SIDED

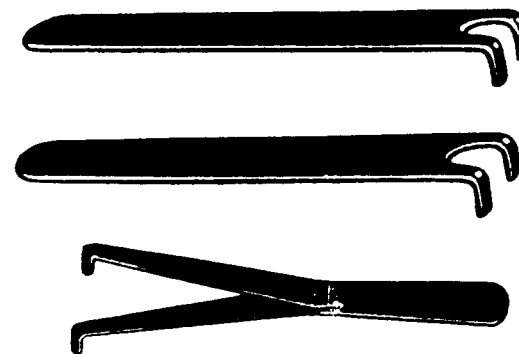

CHAPTER

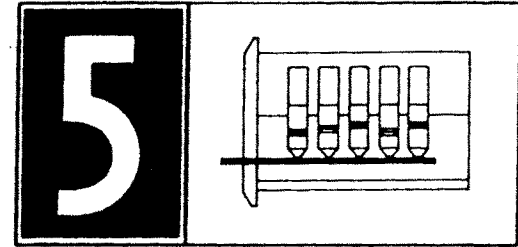

**MOST COMMON
PICKING TECHNIQUES**

The most common techniques for lock picking are raking (where a rake type tool is gently, or in some cases vigorously, pulled along all the tumblers in a rather general way), rather than targeting for specific individual pins as in the case of No. 2, picking each individual chamber. Third is a technique where you would combine the first two. That is, you rake and then specifically target for those pins you may have missed during the initial raking attempts.

Of course, no discussion would be complete without at least mentioning the pick gun. This is a tool that works on the principle of percussion much like cylinder rapping. It is really an effective method once you have mastered the timing necessary to make it work. It consists of the following procedure: Put the tip of the pick gun into the cylinder keyway to be picked. Then, making sure that the pick will strike the pins at a right angle, pull the trigger. At virtually the same moment that the bottom pins are hit, the percussion causes all the top pins to fly straight up towards the top of the pin chamber for an instant, creating an enormous gap. It is in that instant that you must turn the plug with your

FIGURE 14

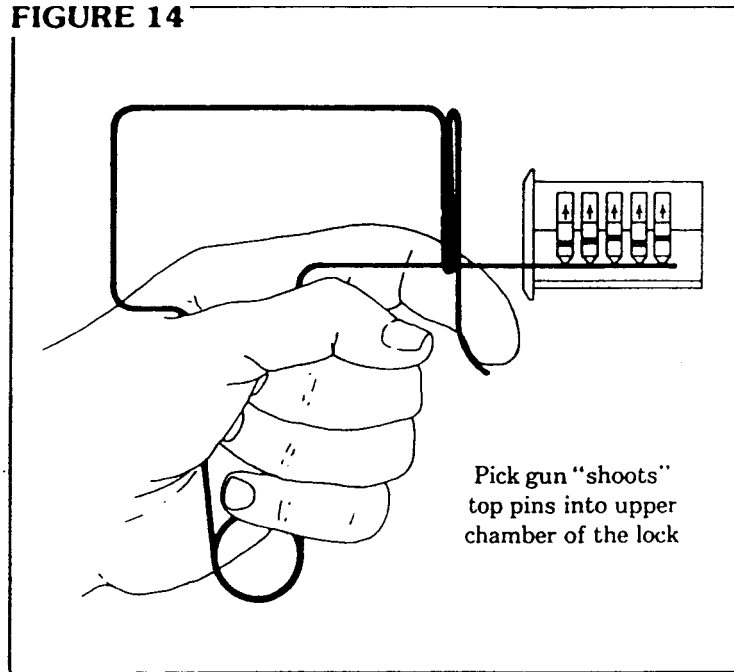

turning tool, opening the lock. It is this ricochet effect that makes this unique tool so valuable in situations involving specialty pins and cylinders.

NOTE: Specialty items will be discussed in the next book, entitled *Advanced Lock Picking*.

CHAPTER

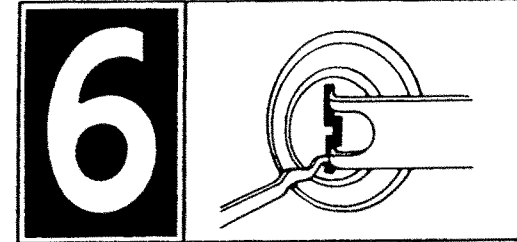

THE LOCKPICKING PROCESS

During the lockpicking process, the barest amount of turning pressure is exerted while you "feel" the condition of the pins in the chambers.

Note: While the ideal condition is matching top and bottom pins in each chamber to maintain the same pressure in each chamber to insure the best possible cylinder operation, only purists would say that this is essential.

FIGURE 15

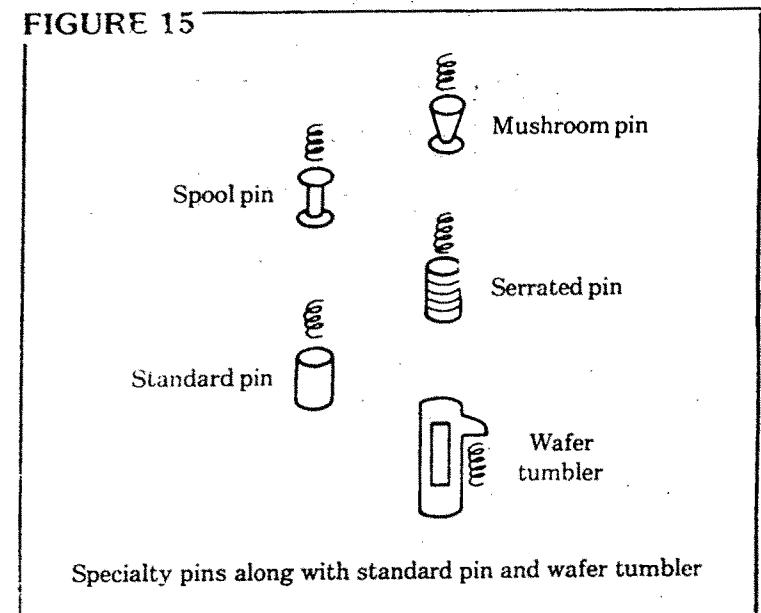

as evidenced by the fact that almost all of the major lock manufacturers have gone to a universal top pin. However, such specialty items as mushroom, spool, and serrated pins still have to be taken into account and treated as special cases (see Figure 15).

There are three conditions in which you can find the pins in any given chamber once you have ascertained that the lock is operating properly and is therefore pickable. The pins, due to the problems with tolerance differentials acquired unavoidably during the manufacturing process, will pick only one at a time no matter how short that span of time may be.

Upon doing your initial raking, the first condition is that the pin is in the unpicked position (see Figure 16).

FIGURE 16

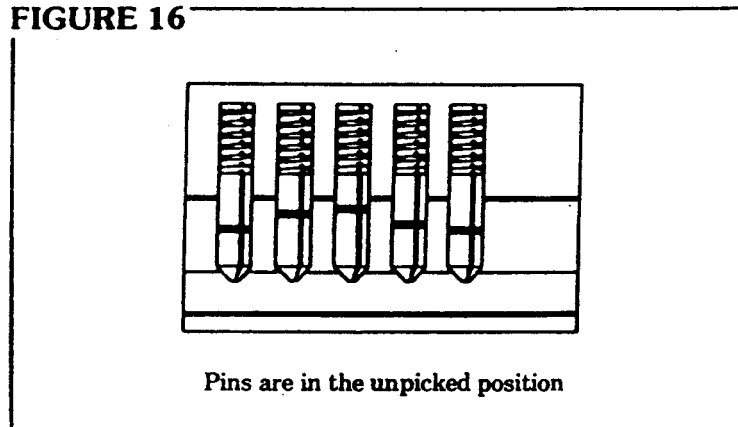

The second possibility is that the pins in the chamber are merely bound (see Figure 17).

The final possibility is that the pins in the chamber are under pressure, but not bound up (see Figure 18).

Simply continue the process of analyzing the condition of each chamber until they are all picked and the lock is opened.

FIGURE 17

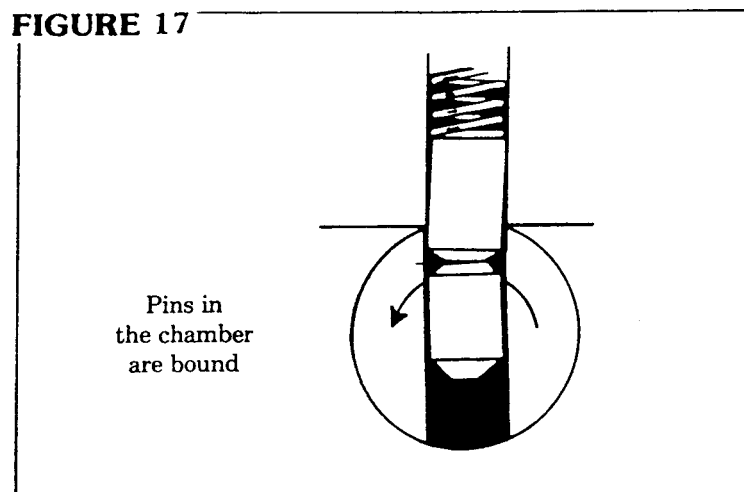

NOTE: The pins will not necessarily pick in their regular order. By this, I mean that pin number 1 will not necessarily pick first. Perhaps, pin No. 1 will pick fifth and pin No. 3 will pick first, and so on.

FIGURE 18

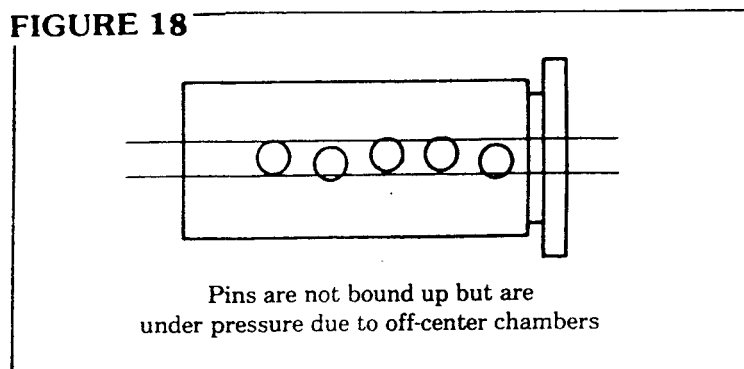

Raking is the most common method used today. It is the fastest to use and the quickest to learn. The raking method will work in opening most cylinders where there is not a sudden change in pin sizes, such as a combination of 7-2-6-1-8, where there is one long pin, one short pin, one long pin, and so on.

FIGURE 19

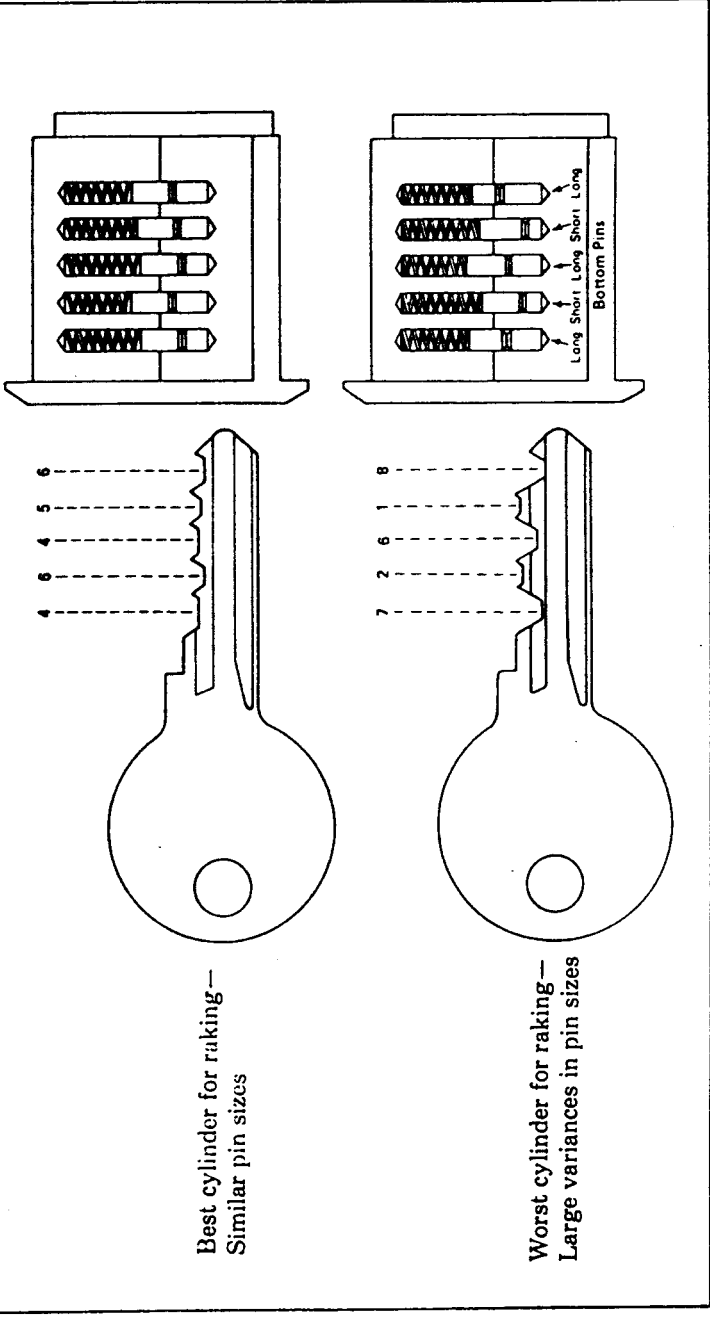
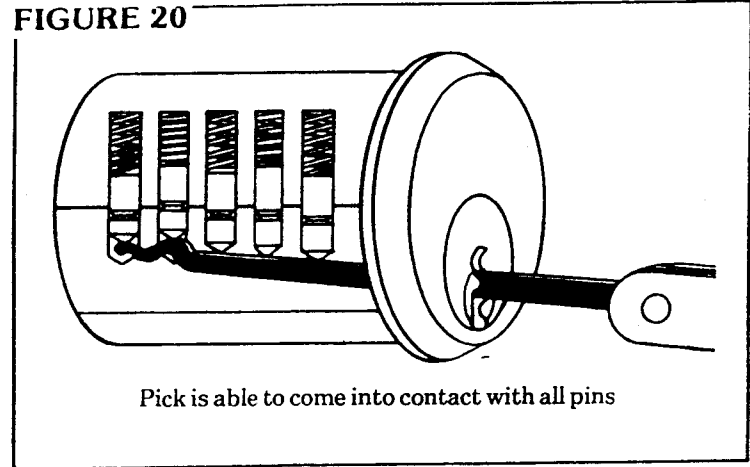

FIGURE 20



The pick you choose for raking should be able to move in and out freely in the upper half of the keyway so it will come into contact with all pins.

FIGURE 21

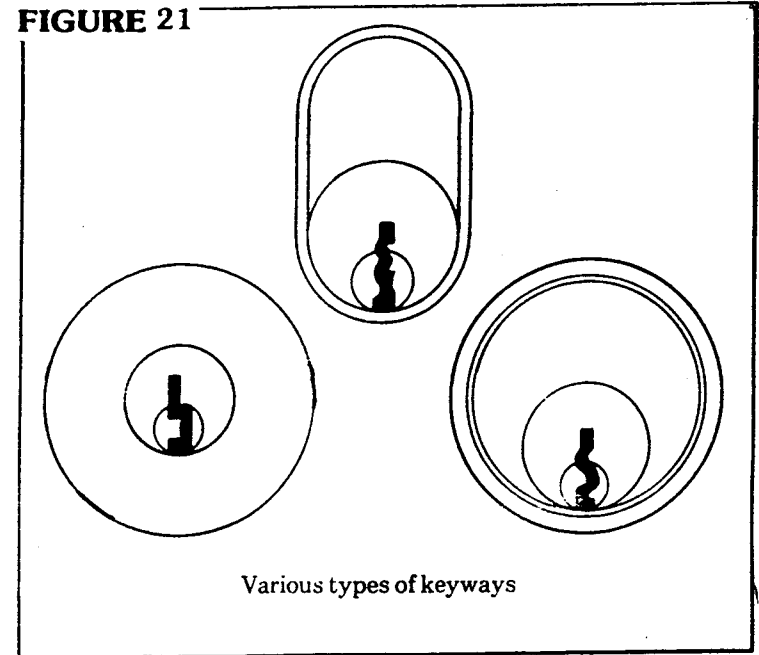
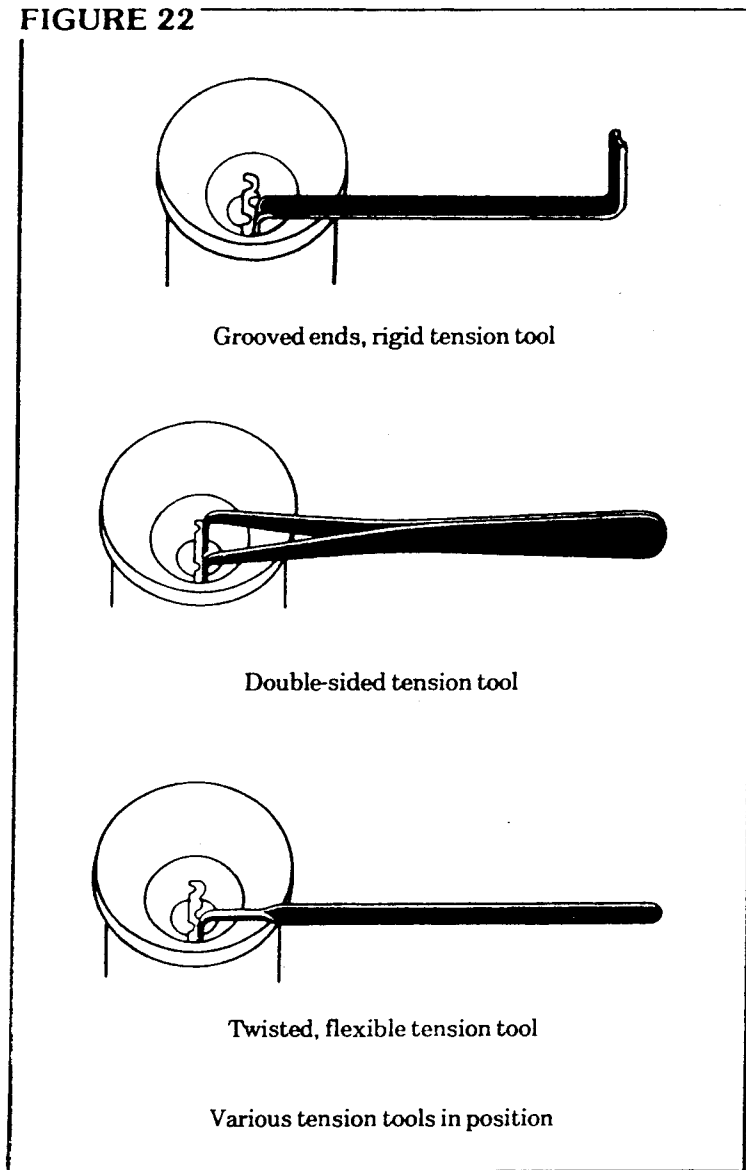
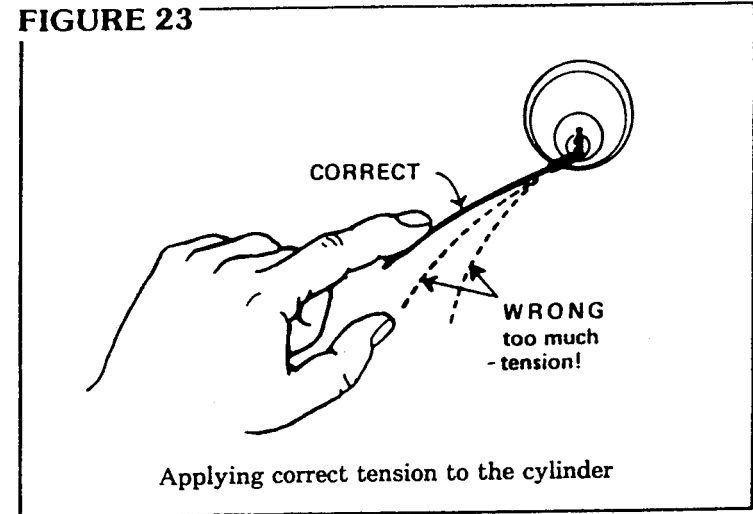

FIGURE 22



The tension tool and its use are the whole trick to raking or picking. Insert tension tool into the bottom of the keyway.

FIGURE 23



Then apply very light tension in the direction to unlock the lock. I stress the point: do not use too much tension. You must develop a light touch with the hand that applies the tension. If tension is too heavy, the top pins will bind below the shear-line and will not allow the breaking-point to meet the shearline.

FIGURE 24

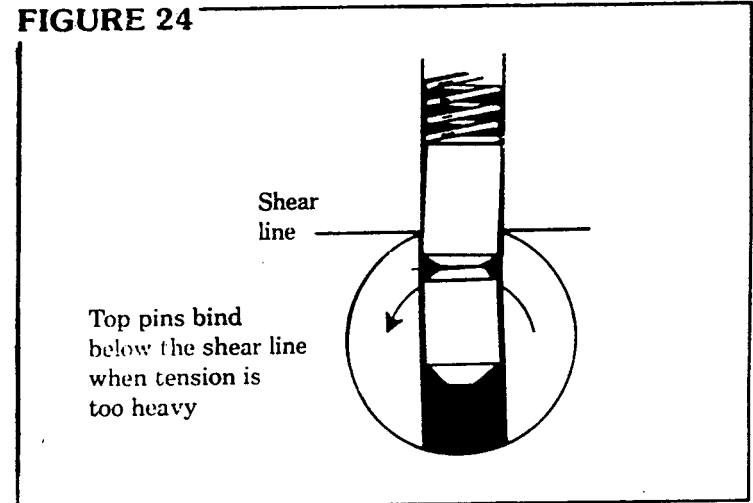
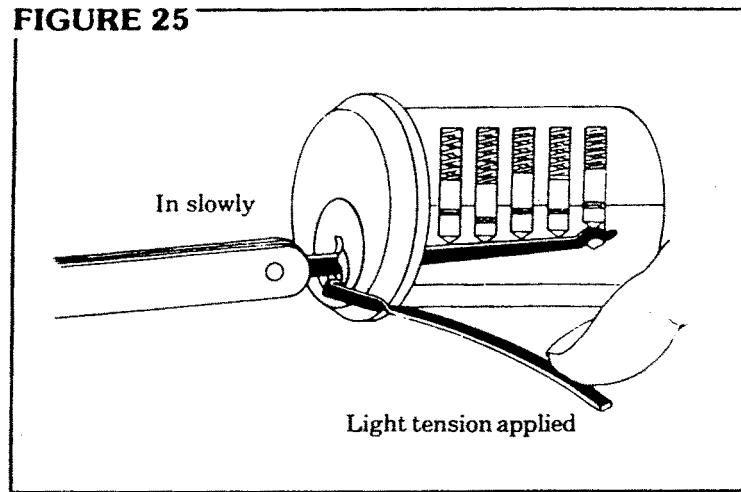
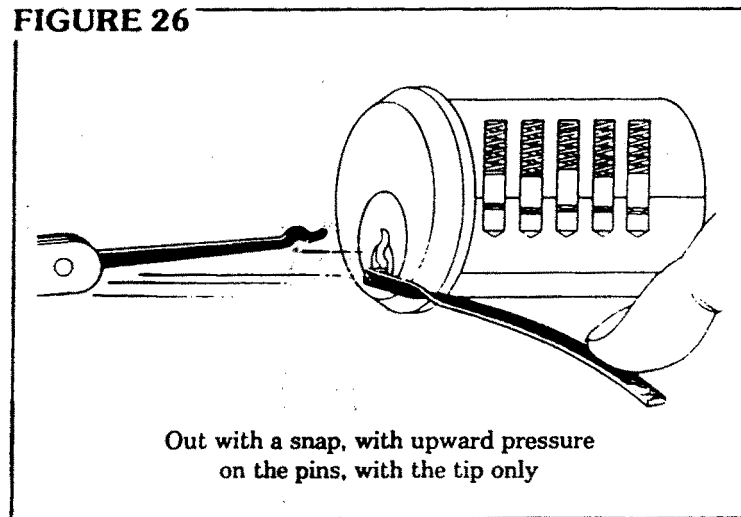

FIGURE 25



Now, with light tension applied, go through the raking operation, in slowly and out with a snap with upward pressure on the pins with the tip only.

FIGURE 26



Repeat this operation three or four times. If the plug does not turn and open the lock, release the tension on

the plug— but, before releasing tension, put your ear close to the cylinder and listen for the sound of the pins clicking back into the down position. Release tension slowly so you can hear all the pins. If there is no sound, you were applying too little or too much tension, not allowing the breaking-point to bind at the shear-line.

FIGURE 27

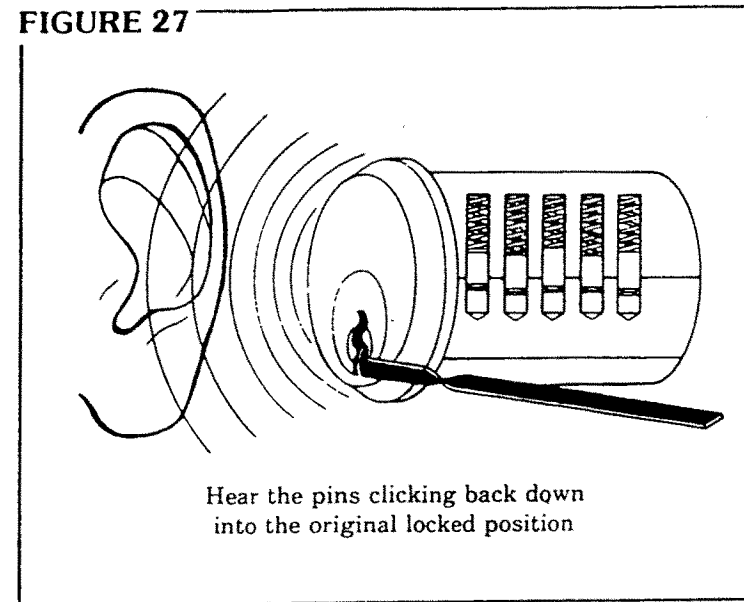

Repeat the raking operation varying the tension, somewhat lighter or heavier than on the first try. With practice, you will gain the right touch in applying tension, and you will find that you can open most cylinders in a few rakings. I suggest you set up a cylinder with only a two pin combination to start with for practice. You should have the cylinder on a large mount, on a door, or held firmly in a vise. Do not try holding the cylinder in your hand while raking it. After you have conquered the two pin combination, go on to a three pin and so on, until you can rake a six or seven pin cylinder. I have found

FIGURE 28

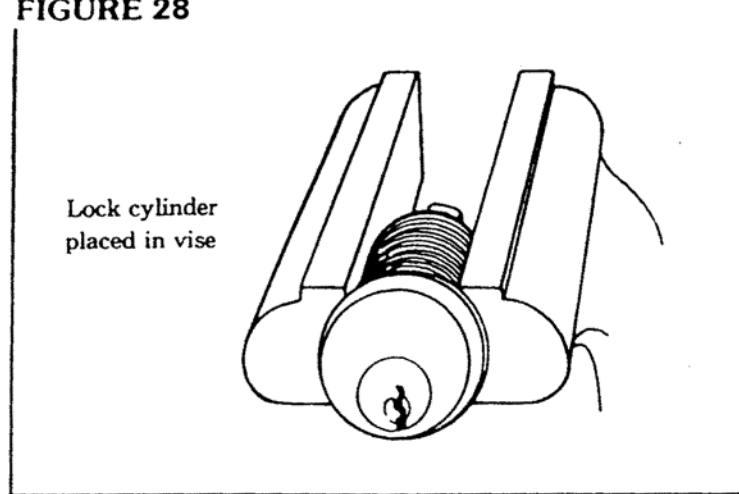

that in some cylinders, where I have tried raking the regular tension and had no luck in opening them, I would then use a slight pulsating tension, but again—not too heavy.

FIGURE 29

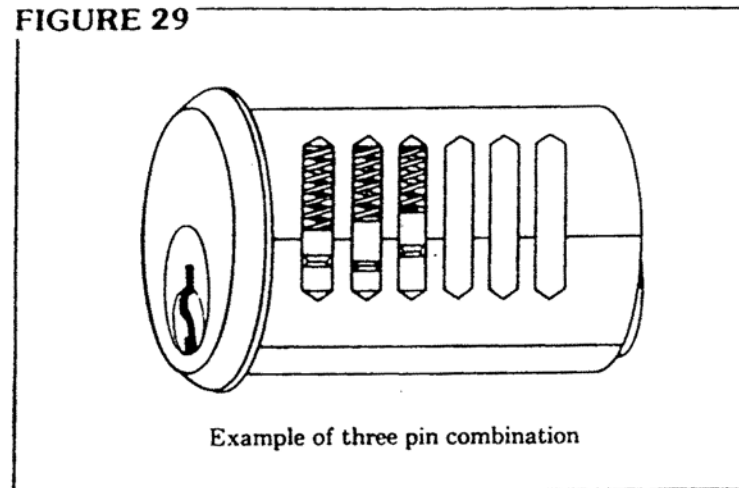

When using the pulsating tension, go from very light to a medium amount of torque, but at all times, when

FIGURE 30

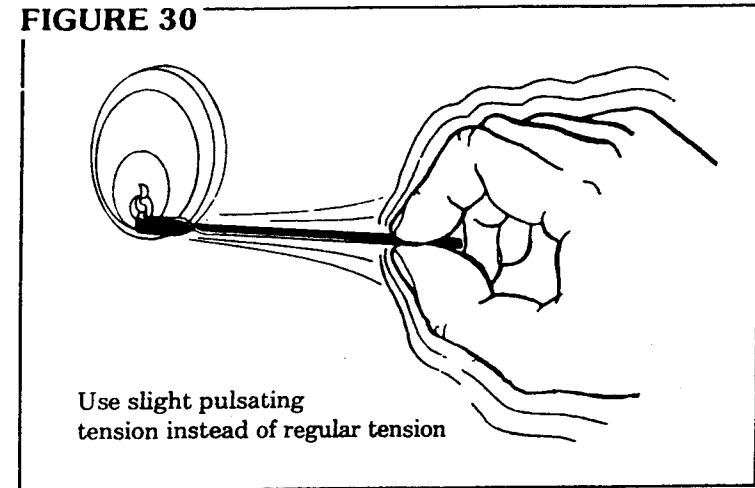

pulsating to the very light, do not lose tension on the pins completely. You will find, in raking cylinders, some will open very easily, regardless of the pin combination. This is due to the poor construction of some cylinders. As a rule, the lower the price of the cylinder, the easier it picks. The low-priced cylinder is manufactured with greater clearances on all parts so that the cost of

FIGURE 31

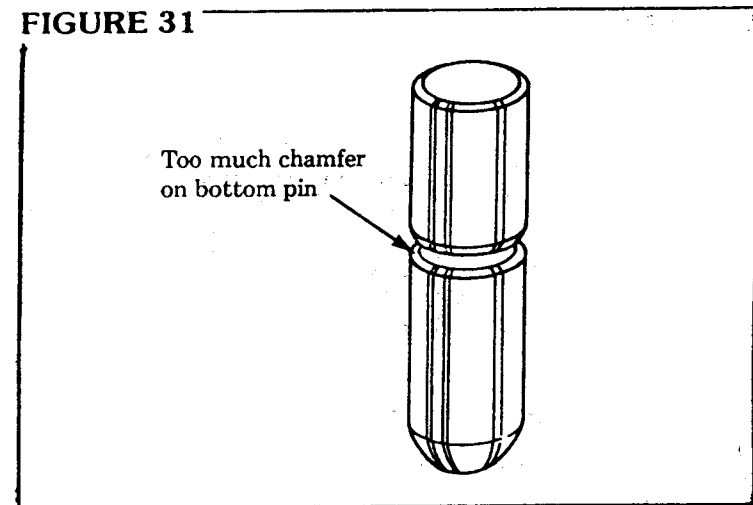

assembly will be kept low. The following characteristics are commonly found in low-priced cylinders; too much chamfer on the top of the bottom pin; die-cast plug and body with poor hole alignment; and, over-sized pin holes; too much clearance between plug and body.

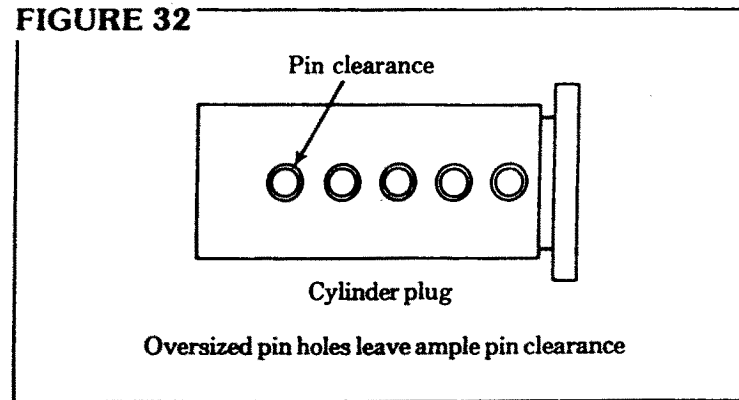

This is an aid for the manufacturer in the assembly of the cylinder, but it is also an aid for the locksmith who must pick the cylinder. Higher-priced cylinders are manufactured with much less clearance. They are usually constructed from brass bar stock, both body and

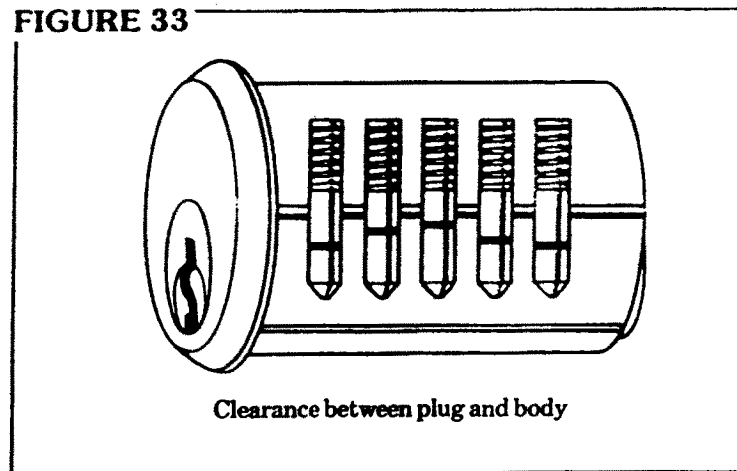

plug. The pin holes are drilled and reamed for a close fit with the pins and when the plug and body are drilled while together the hole alignment is excellent. But, in spite of the fine construction, you still can pick or rake it open. It might take a little longer—it might take some adjustment in the tension—it may have to be picked instead of being raked, but you can do it. No matter how minute the clearances are, there are clearances, or the parts would not go together and this is what makes picking and raking possible. At times you will come across a cylinder that you can not pick or rake in a reasonable length of time. Even the expert runs into these same problems. Do not become discouraged. Most locks can be picked or raked in a short time. Do not waste hours working on an extremely difficult cylinder. You will soon be able to determine just how much time to spend on picking or raking a cylinder before resorting to other methods such as drilling.

I have not gone into the handling of the tools. You will probably develop your own personal grip, but for my suggestions see Figure 34.

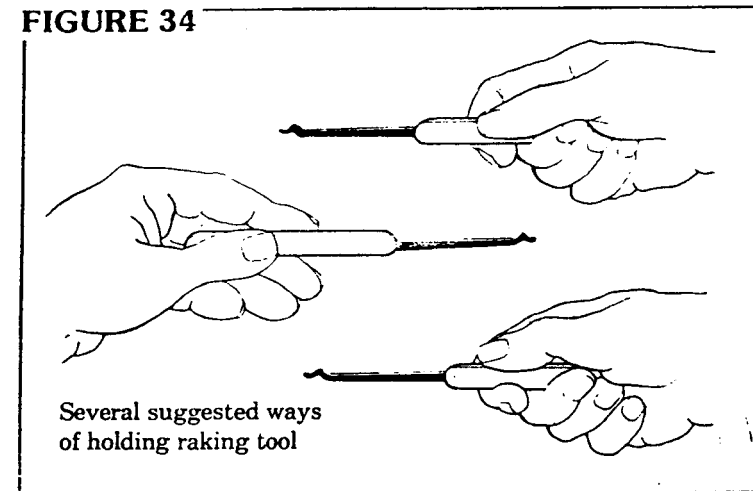

Try any one of the grips shown in the illustrations. The most important thing to remember at this point, is that the tools must be comfortable in your hands. I suggested at the start that you use a medium weight and length tension tool, but after you have been raking for a while, you may prefer to try your skill with a light weight or rigid tension tool. You will soon find which tool is best for you.

FIGURE 35

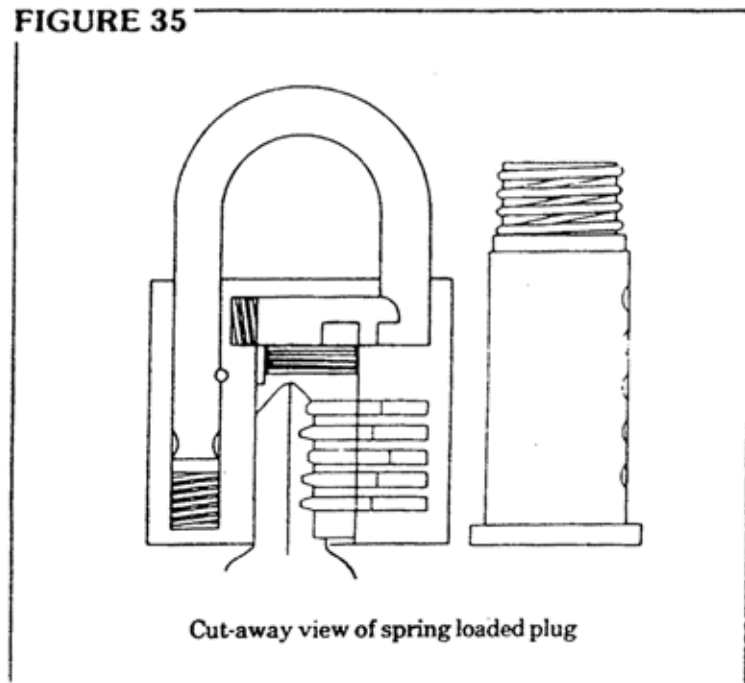

When raking a lock which has a spring-loaded plug such as most padlocks see Figure 35.

As you apply tension to the plug, you will be working against the direct pressure of a spring which is used in the locking of the shackle and returning of the plug to the locked position. This lock will require more tension. Use one of the rigid tools (see Figure 13).

Also if you push inward on the shackle of the padlock, it will relieve some of the spring pressure on the plug (see Figure 36).

FIGURE 36

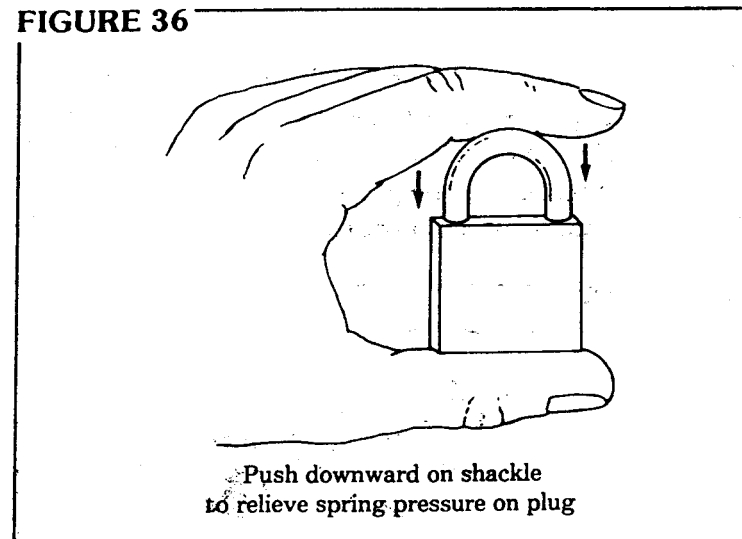

If you discover that you have raked the plug in the wrong direction and the lock will not open, this is no problem. If the lock was very easy to pick, just apply tension in the other direction and re-rake it open. Now, if

FIGURE 37

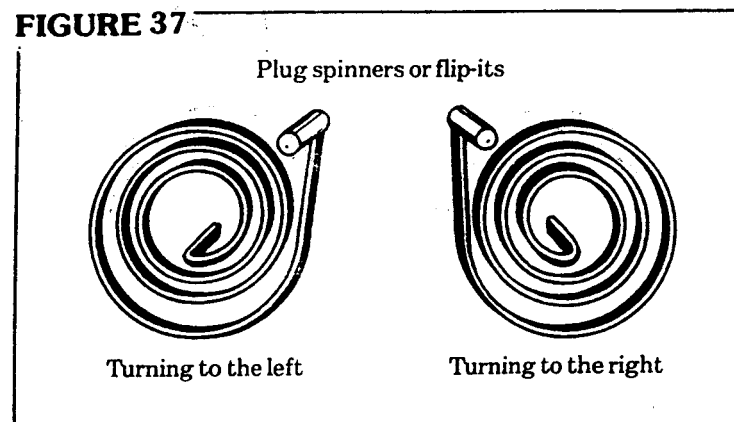

you have raked the lock in the wrong direction and opened it with difficulty, hold it right there. Do not lock it and re-rake it. There is a tool just for this purpose (see Figure 37).

This pair of coiled springs with handles, one coiled to the left and one coiled to the right, will be referred to as Flip-Its. The first procedure is to determine if the left or right hand Flip-It is required. This is done by facing the lock and visualizing the handle pointing towards you and the flange inserted into the top of the keyway. If the plug is

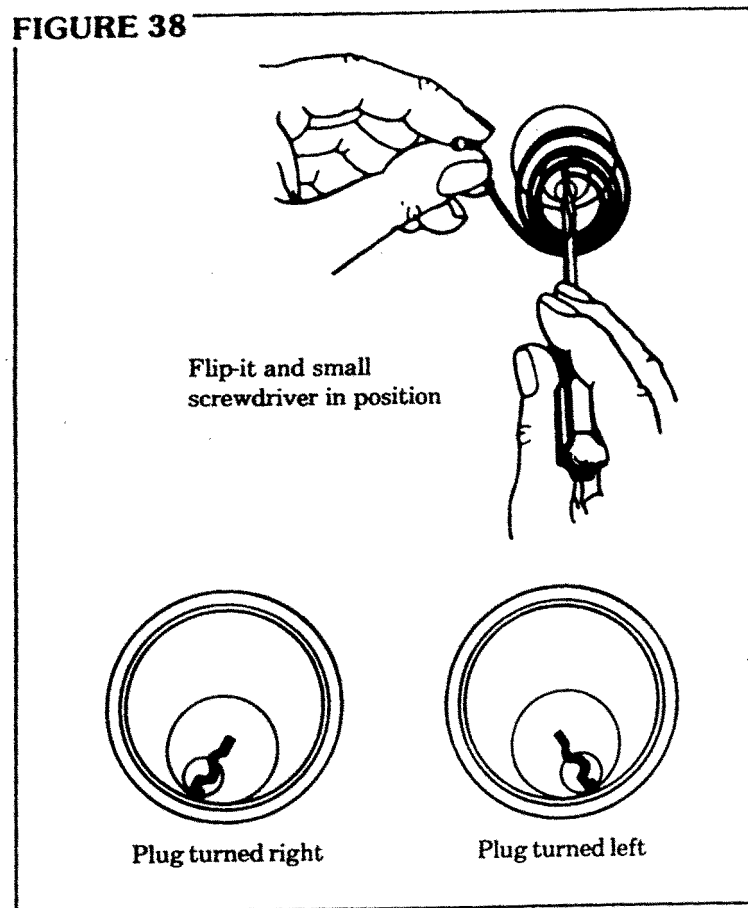

turned to the right, your handle will be to the right of the cylinder — and if the plug is turned to the left, your handle will be to the left of the cylinder (see Figure 38).

Now, say that your plug is turned to the left and this is in the wrong direction for opening the lock. You may have to get the plug to go to the right. Carefully remove the pick and tension tool. Next insert a small screwdriver into the lower portion of the keyway on the raked lock. Keep the tension on the plug with the screwdriver. Do not allow the plug to slip into the original locked position. You already have chosen the proper flip-it. Now place the centered flange end of the coil into the upper section of the keyway. Grasping the small handle of the coil, strongly wind the flip-it toward the direction into which the plug is to be turned. This will be to the right. At the same time, remember to keep the plug in position firmly with the screwdriver. With a quick yank, pull back the screwdriver. The tension of the flip-it will snap the plug over to the opposite direction quickly enough to prevent the pins from falling back into their locked positions. After practicing this procedure, you will find the tool is quite easy to use. Occasionally, you will come across a cylinder that rakes easier in one direction than the other and if you have to rake it into the unlocking direction, you will find this tool quite handy.

Now, for the method of picking. When picking a cylinder, you will be lifting one pin at a time, for this we would use a hook-type pick (see Figure 8).

You apply tension in the same manner as you did when raking. The insert the pick all the way into the keyway and raise up the last pin until the breaking point will bind at the shear-line (see Figure 39).

Then proceed to the next pin until you work your way out of the keyway. Be sure to keep tension on the plug

FIGURE 39

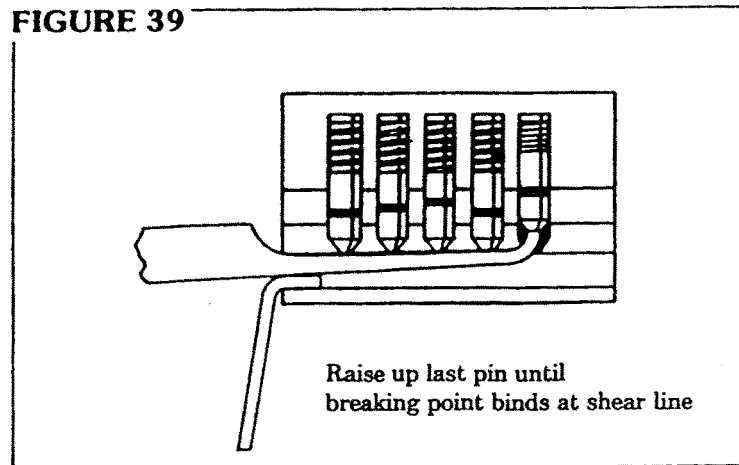

during the entire process. After each pin is picked, you will feel the bottom pin become free of the downward spring pressure. But, don't be fooled just because the bottom pin is free. This doesn't mean it's picked. You may have been applying too much tension to the plug and caused the top pin to bind below the shear-line (see Figure 40).

FIGURE 40

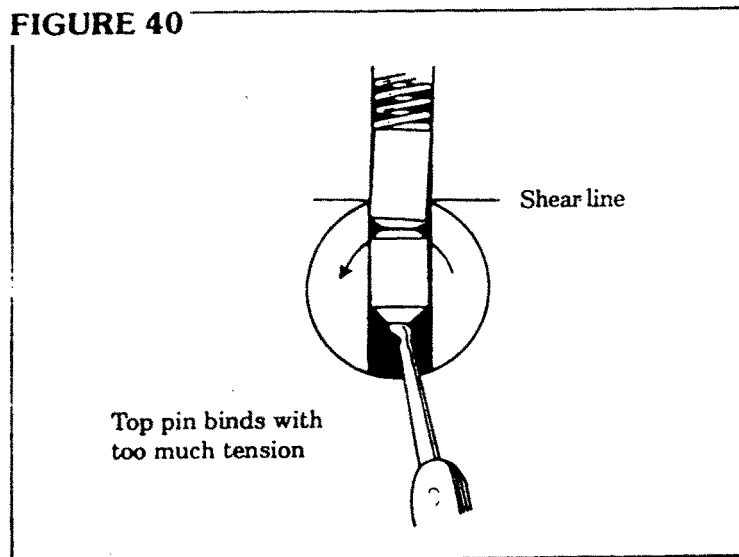

When it is properly picked, you should feel a very slight give in the turning of the plug (see Figure 41).

That slight turning of the plug will become greater with each pin you pick until it turns fully when you have picked all the pins. Always remember, the tension must not be too heavy. The whole secret of raking or picking is in

FIGURE 41

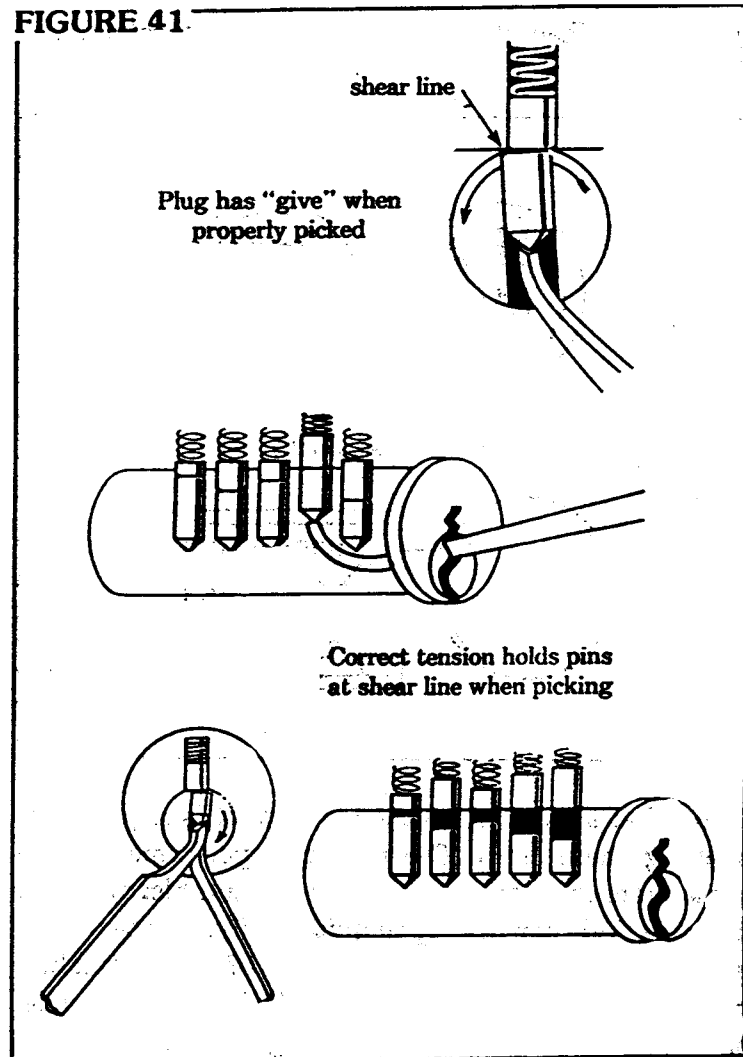

the tension. You must develop that touch with your tension hand. To practice picking, do so as I suggested in the raking method. Set up a cylinder with two pins, pick it a few times, then set it up with three pins, and so on until you are able to pick a six or even a seven-pin cylinder.

All the previous directions have been for pin-tumbler cylinders. When dealing with the disc-tumbler, see Figure 42.

FIGURE 42

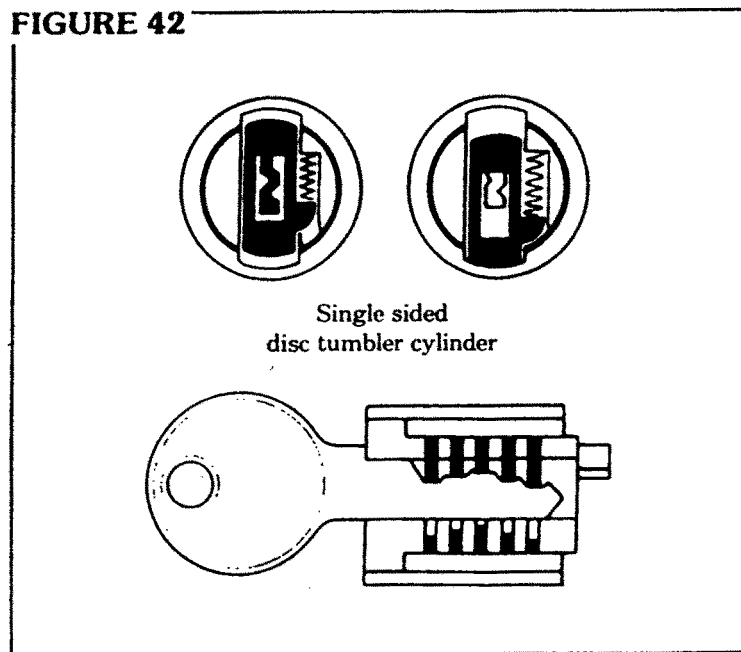

Single sided
disc tumbler cylinder

I find that the raking method is all that is required for opening these locks. The raking is performed in the same manner as that of raking a pin-tumbler cylinder. You will find they rake open quite easily. The tension is also used in the same manner as that of the pin-tumbler cylinders. The only variation would be in the double-sided disc or wafer cylinder (see Figure 43).

FIGURE 43

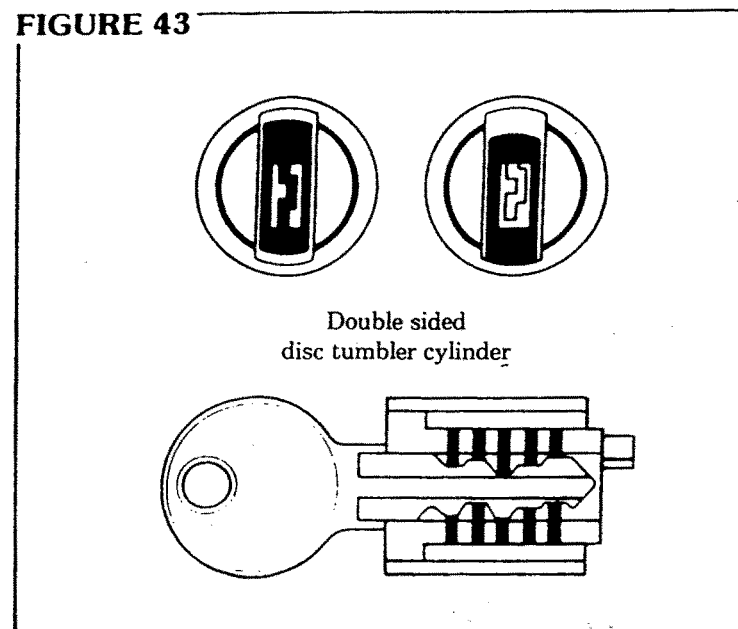

Double sided
disc tumbler cylinder

The double-sided cylinder usually requires a different tension tool (see Figure 13).

Double-sided locks can be raked in two different ways. Number 1—with the use of a standard raking tool—but I suggest the single or double ball pick which I have found to work very well. Apply tension in the same manner as you did with all other picking and raking. However, if you are using a double-sided tension tool, it will fit in the top and bottom of the keyway (see Figure 44).

FIGURE 44

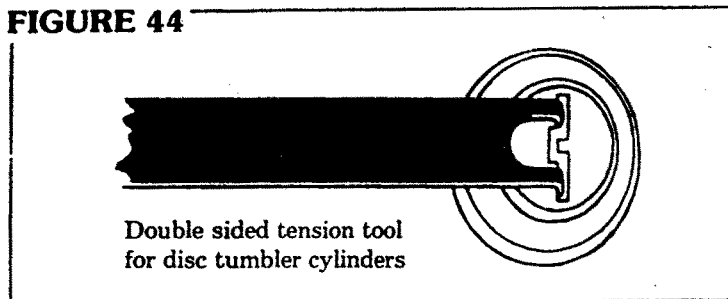

Double sided tension tool
for disc tumbler cylinders

After you have applied tension, you begin to rake the upper discs or wafers as you would have in the single-sided lock. When you feel a slight give in the tension of the plug, you switch your raking to the bottom—but do not let up on the tension. You rake the lower discs or wafers in the same way as you did the upper ones, but use a downward pressure when pulling the rake out (see Figure 45).

FIGURE 45

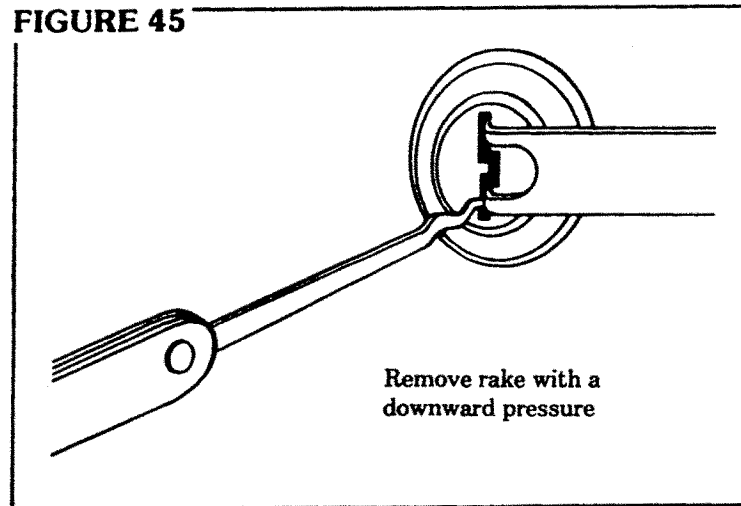

It would be like raking a pin tumbler cylinder that was installed upside-down. Now for the second method of raking double-sided locks. Use double-sided picks (see Figure 46).

You will find these tools very effective in opening most disc-tumbler double-sided locks. With these tools, no tension tool is required if there is no spring tension on the plug. As a general rule, spring tension will be found only in padlocks or shunt switches (see Figure 47).

Insert tip of picking tool all the way into the keyway. Rock tool rather rapidly up and down while pushing slowly and gently inward. If pick binds part way in,

FIGURE 46

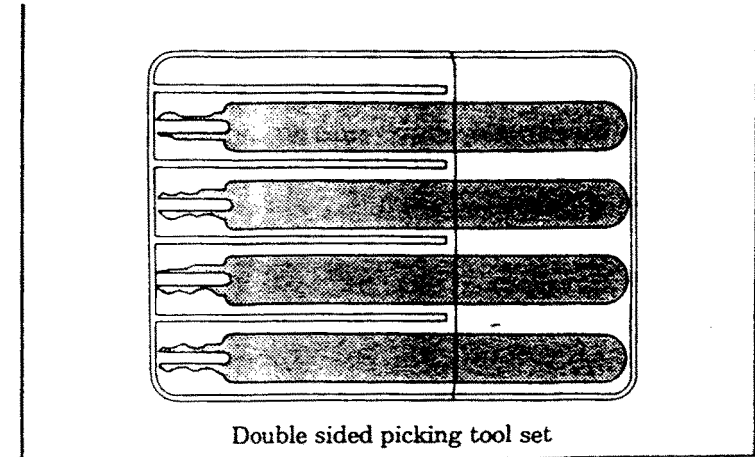
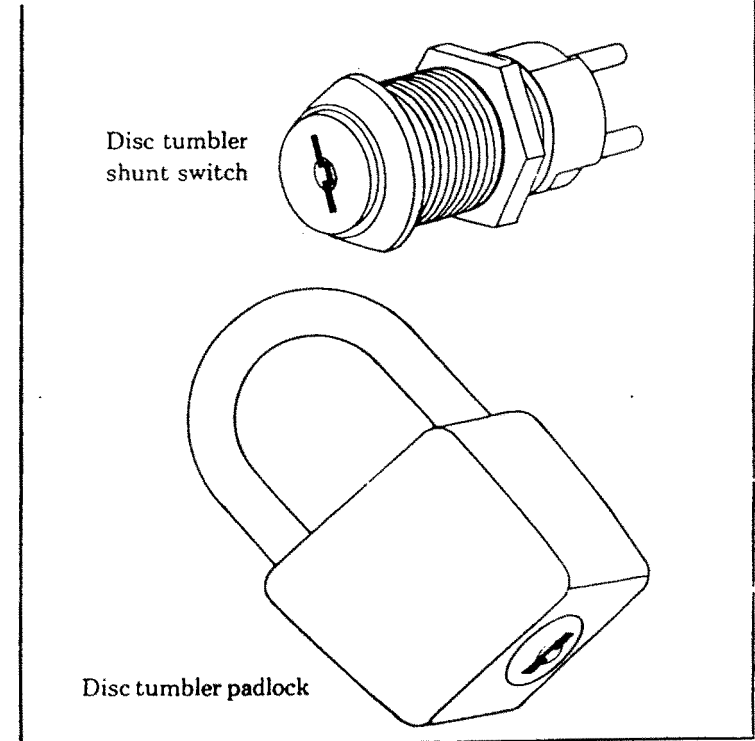
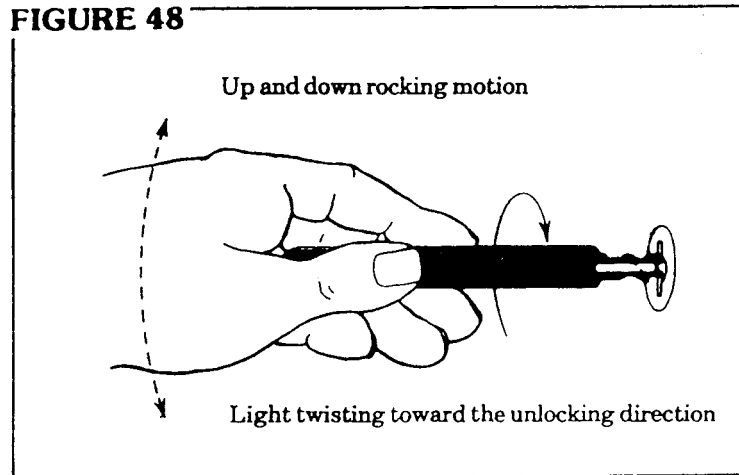

FIGURE 47



remove tool and reverse to pick prongs on other side and try again. A pick whose bittings are incompatible with the key-way alignment will not go all the way in. Do not force. When tool is inserted all the way picking action is begun by a moderately rapid up and down rocking motion together with a twisting toward the unlocking direction (see Figure 48).

FIGURE 48



This up and down rocking should not exceed a one and one-half inch arc at the handle end (see Figure 49).

Combine the rocking and the light twisting motion with a slow in and out raking. Forcing the tool would distort

FIGURE 49

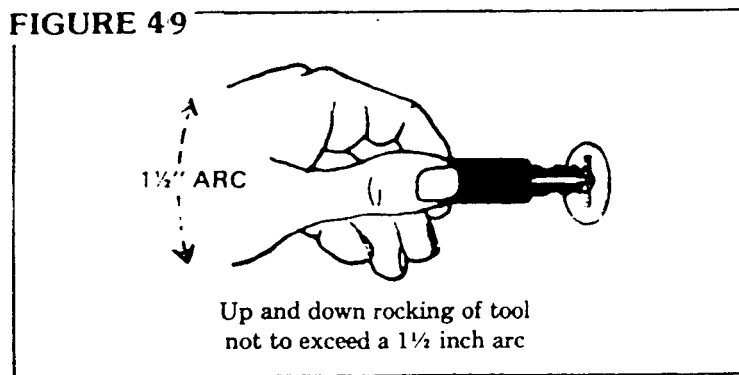

the prongs and may lead to breakage. Each of the four tools should be tried out using this action. Explore all eight possibilities until a lock opening is made. After removal of the pick, make sure the fork ends are straight. Re-bend to a parallel position if it becomes necessary. Most double-sided cylinders unlock to the right, clockwise. When picking the double-sided padlocks or shunt switches a heavier tension is required. We suggest the use of the VV-6 (see Figure 13).

In this case, the tension tool is usually required for these types of locks. Also, the pressing down on the shackle at the same time while raking will help relieve some of the turning tension. You will find both methods work very well after a little practice.

By following these instructions, you should soon become proficient in the raking and picking of pin-tumblers, single and double-sided disc and wafer locks.

NOTES

CONCLUSIONS

Lock picking can be an effective method for opening locks, only if certain conditions present themselves (i.e. the pins must be free and the cylinder, in general, operational). However, we must not let ego get in the way when we determine the best method for a given situation. After all, there is nothing wrong with drilling a lock to get it open, if that is the most time efficient and cost effective method for your customer. Remember, labor is more expensive (in most cases) than product. It is not logical to stand outside picking a lock for one hour, even if you finally do open it, when you can drill and replace most common cylinders in mere moments.

Picking is a skill that will only improve with practice, experience, and dedication, but the rewards in a large variety of situations will be incalculable in terms of time and money.

NEW!
Reformatted Edition

Distribution

Copyright 1987, 1991 Theodore T. Tool. All rights reserved. Permission to reproduce this document on a non-profit basis is granted provided that this copyright and distribution notice is included in full. The information in this booklet is provided for educational purposes only.

August 1991 revision.



Contents

1 It's Easy	4
2 How a Key Opens a Lock	5
3 The Flatland Model	7
4 Basic Picking & The Binding Defect	9
5 The Pin Column Model	11
6 Basic Scrubbing	17
7 Advanced Lock Picking	21
7.1 Mechanical Skills	21
7.2 Zen and the Art of Lock Picking	21
7.3 Analytic Thinking	22
8 Exercises	23
8.1 Exercise 1: Bouncing the pick	23
8.2 Exercise 2: Picking pressure	24
8.3 Exercise 3: Picking Torque	24
8.4 Exercise 4: Identifying Set Pins	25
8.5 Exercise 5: Projection	26
9 Recognising and Exploiting Personality Traits	27
9.1 Which Way To Turn	27
9.2 How Far to Turn	29
9.3 Gravity	29
9.4 Pins Not Setting	29
9.5 Elastic Deformation	30

9.6 Loose Plug	30
9.7 Pin Diameter	32
9.8 Bevelled Holes and Rounded pins	32
9.9 Mushroom Driver Pins	34
9.10 Master Keys	36
9.11 Driver or Spacer Enters Keyway	38
9.12 Vibration Picking	39
9.13 Disk Tumblers	40
10 Final Remarks	42
A Tools	43
A.1 Pick Shapes	43
A.2 Street cleaner bristles	44
A.3 Bicycle spokes	47
A.4 Brick Strap	47
B Legal Issues	48

Chapter 1: It's Easy

The big secret of lock picking is that it's easy. Anyone can learn how to pick locks.

The theory of lock picking is the theory of exploiting mechanical defects. There are a few basic concepts and definitions but the bulk of the material consists of tricks for opening locks with particular defects or characteristics.

The organisation of this manual reflects this structure. The first few chapters present the vocabulary and basic information about locks and lock picking. There is no way to learn lock picking without practicing, so one chapter presents a set of carefully chosen exercises that will help you learn the skills of lock picking.

The document ends with a catalogue of the mechanical traits and defects found in locks and the techniques used to recognize and exploit them. The first appendix describes how to make lock picking tools. The other appendix presents some of the legal issues of lock picking.

The exercises are important. The only way to learn how to recognize and exploit the defects in a lock is to practice. This means practicing many times on the same lock as well as practicing on many different locks. Anyone can learn how to open desk and filing cabinet locks, but the ability to open most locks in under thirty seconds is a skill that requires practice.

Before getting into the details of locks and picking, it is worth pointing out that lock picking is just one way to bypass a lock, though it does cause less damage than brute force techniques. In fact, it may be easier to bypass the bolt mechanism than to bypass the lock.

It may also be easier to bypass some other part of the door or even avoid the door entirely. Remember: *There is always another way, usually a better one.*

Chapter 2: How a Key Opens a Lock

This chapter presents the basic workings of pin tumbler locks, and the vocabulary used in the rest of this booklet. The terms used to describe locks and lock parts vary from manufacture to manufacture and from city to city, so even if you already understand the basic workings of locks, you should look at *Figure 2.1* for the vocabulary.

Knowing how a lock works when it is opened by a key is only part of what you need to know. You also need to know how a lock responds to picking. Chapters 3 and 5 present models which will help you understand a lock's response to picking.

Figure 2.1 introduces the vocabulary of real locks. The key is inserted into the keyway of the plug. The protrusions on the side of the keyway are called wards. Wards restrict the set of keys that can be inserted into the plug. The plug is a cylinder which can rotate when the proper key is fully inserted. The non-rotating part of the lock is called the hull. The first pin touched by the key is called pin one. The remaining pins are numbered increasingly toward the rear of the lock.

The proper key lifts each pin pair until the gap between the key pin and the driver pin reaches the sheer line. When all the pins are in this position, the plug can rotate and the lock can be opened. An incorrect key will leave some of the pins protruding between the hull and the plug, and these pins will prevent the plug from rotating.

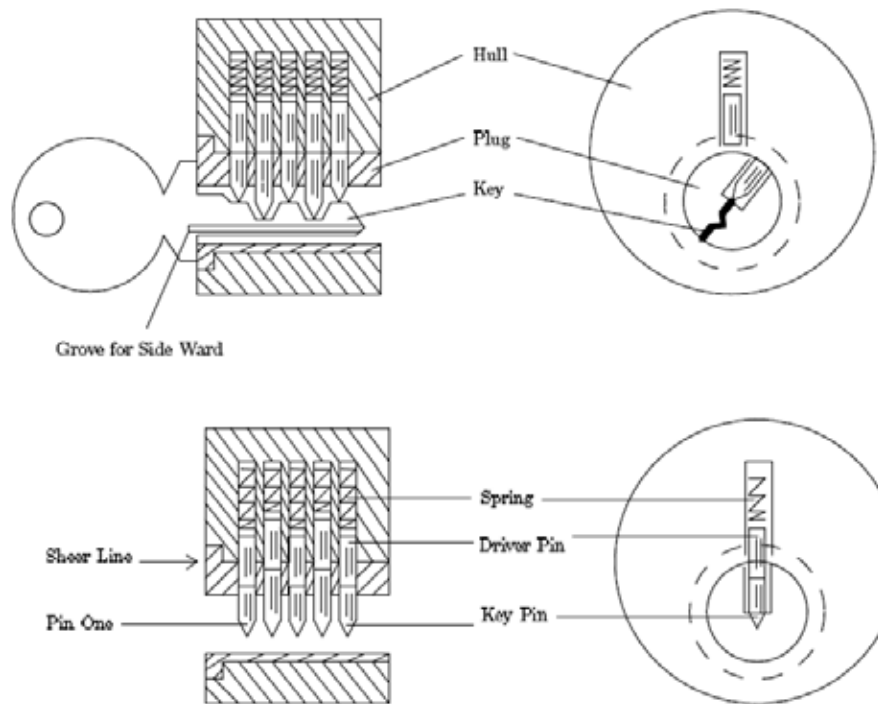

Figure 2.1: Workings of pin tumbler locks

Chapter 3: The Flatland Model

In order to become good at picking locks, you will need a detailed understanding of how locks work and what happens as it is picked. This document uses two models to help you understand the behaviour of locks. This chapter presents a model that highlights interactions between pin positions. Chapter 4 uses this model to explain how picking works. Chapter 9 will use this model to explain complicated mechanical defects.

The "Flatland" model of a lock is shown in *Figure 3.1*. This is not a cross section of a real lock. It is a cross section of a very simple kind of lock. The purpose of this lock is to keep two plates of metal from sliding over each other unless the proper key is present. The lock is constructed by placing the two plates over each other and drilling holes which pass through both plates.

The figure shows a two-hole lock. Two pins are placed in each hole such that the gap between the pins does not line up with the gap between the plates. The bottom pin is called the key pin because it touches the key. The top pin is called the driver pin. Often the driver and key pins are just called the driver and the pin. A protrusion on the underside of the bottom plate keeps the pins from falling out, and a spring above the top plate pushes down on the driver pin.

If the key is absent, the plates cannot slide over each other because the driver pins pass through both plates. The correct key lifts the pin pairs to align the gap between the pins with the gap between the plates. See *Figure 3.3*. That is, the key lifts the key pin until its top reaches the lock's shear line. In this configuration, the plates can slide past each other.

Figure 3.3 also illustrates one of the important features of real locks. There is always a sliding allowance. That is, any parts which slide past each other must be separated by a gap. The gap between the top and bottom plates allows a range of keys to open the lock. Notice that the right key pin in *Figure 3.3* is not raised as high as the left pin, yet the lock will still open.

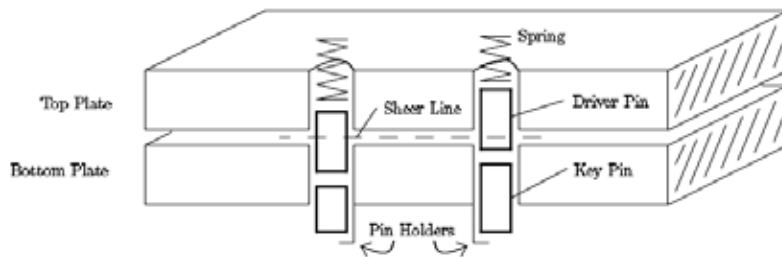

Figure 3.1: Flatland model of a lock

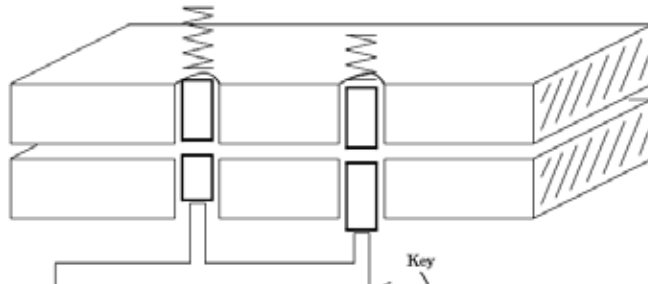

Figure 3.2: (a) Flatland key raises pins

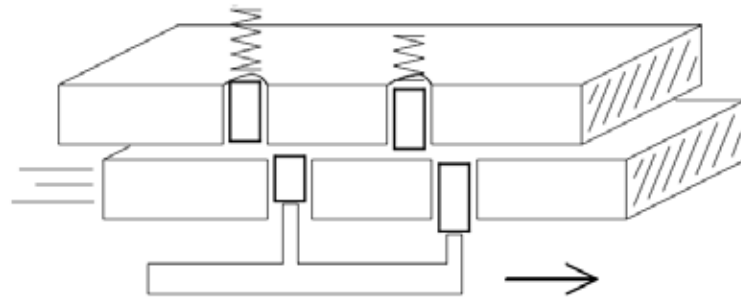

Figure 3.3: (b) Proper key allows plates to slide

Chapter 4: Basic Picking & The Binding Defect

The Flatland model highlights the basic defect that enables lock picking to work. This defect makes it possible to open a lock by lifting the pins one at a time, and thus you don't need a key to lift all the pins at the same time. *Figure 4.3* shows how the pins of a lock can be set one at a time.

The first step of the procedure is to apply a shear force to the lock by pushing on the bottom plate. This force causes one or more of the pins to be scissored between the top and bottom plate. The most common defect in a lock is that only one pin will bind.

Figure 4.3a shows the left pin binding. Even though a pin is binding, it can be pushed up with a picking tool, see *Figure 4.3b*. When the top of the key pin reaches the shear line, the bottom plate will slide slightly. If the pick is removed, the driver pin will be held up by the overlapping bottom plate, and the key pin will drop down to its initial position, see *Figure 4.3c*. The slight movement of the bottom plate causes a new pin to bind. The same procedure can be used to set the new pin.

Thus, the procedure for one pin at a time picking a lock is to apply a shear force, and the pin which is binding the most, and push it up. When the top of the key pin reaches the shear line, the moving portion of the lock will give slightly, and driver pin will be trapped above the shear line. This is called setting a pin.

Chapter 9 discusses the different defects that cause pins to bind one at a time.

1. Apply a shear force.
2. Find the pin that is binding the most.
3. Push that pin up until you feel it set at the shear line.
4. Go to step 2

Table 4.1: Figure 5: Picking a lock one pin at a time.

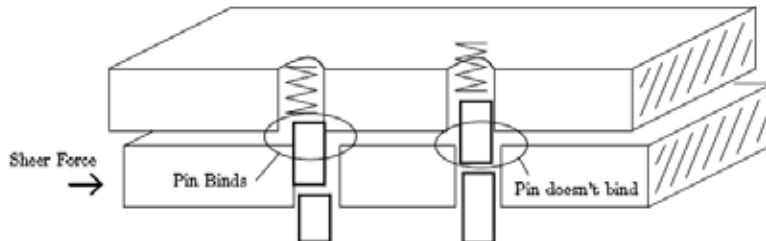

Figure 4.1: (a) Shear force causes driver to bind

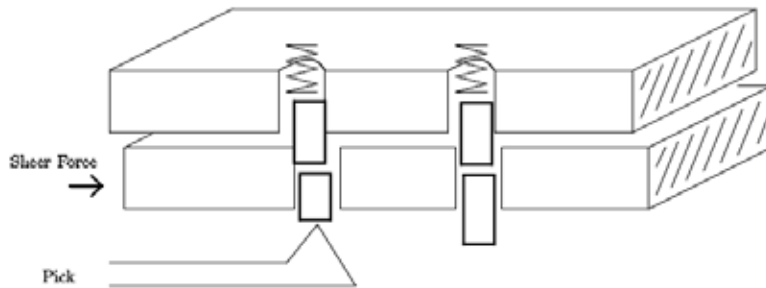

Figure 4.2: (b) Pick lifts the binding pin

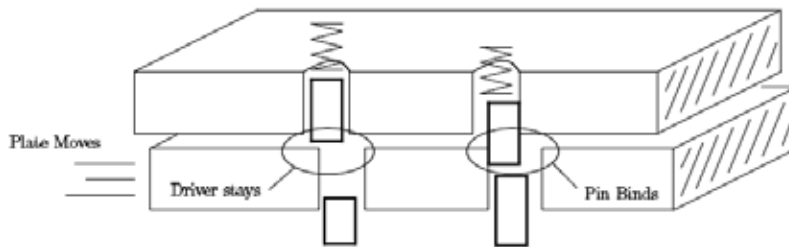

Figure 4.3: (c) Left driver sets and right driver binds

Chapter 5: The Pin Column Model

The Flatland model of locks can explain effects that involve more than one pin, but a different model is needed to explain the detailed behaviour of a single pin. See *Figure 5.1*. The pin-column model highlights the relationship between the torque applied and the amount of force needed to lift each pin. It is essential that you understand this relationship.

In order to understand the "feel" of lock picking you need to know how the movement of a pin is effected by the torque applied by your torque wrench (tensioner) and the pressure applied by your pick. A good way to represent this understanding is a graph that shows the minimum pressure needed to move a pin as a function of how far the pin has been displaced from its initial position. The remainder of this chapter will derive that force graph from the pin-column model.

Figure 5.2 shows a single pin position after torque has been applied to the plug. The forces acting on the driver pin are the friction from the sides, the spring contact force from above, and the contact force from the key pin below. The amount of pressure you apply to the pick determines the contact force from below.

The spring force increases as the pins are pushed into the hull, but the increase is slight, so we will assume that the spring force is constant over the range of displacements we are interested in. The pins will not move unless you apply enough pressure to overcome the spring force. The binding friction is proportional to how hard the driver pin is being scissored between the plug and the hull, which in this case is proportional to the torque.

The more torque you apply to the plug, the harder it will be to move the pins. To make a pin move, you need to apply a pressure that is greater than the sum of the spring and friction forces. When the bottom of the driver pin reaches the shear line, the situation suddenly changes.

See *Figure 5.3*. The friction binding force drops to zero and the plug rotates slightly (until some other pin binds). Now the only resistance to motion is the spring force. After the top of the key pin crosses the gap between the plug and the hull, a new contact force arises from the key pin striking the hull. This force can be quite large, and it causes a peak in the amount of pressure needed to move a pin.

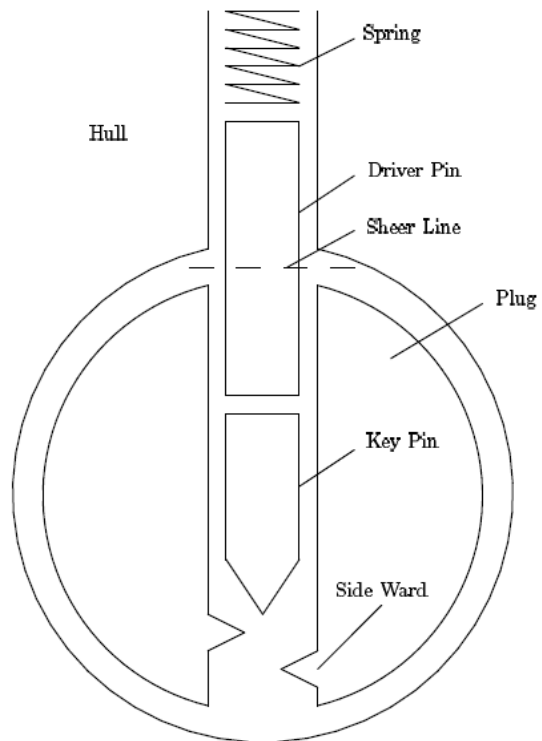

Figure 5.1: The pin-column model

If the pins are pushed further into the hull, the key pin acquires a binding action like the driver pin had in the initial situation. See Figure 5.4. Thus, the amount of pressure needed to move the pins before and after the shear line is about the same. Increasing the torque increases the required pressure. At the shear line, the pressure increases dramatically due to the key pin hitting the hull. This analysis is summarized graphically in figure 5.5.

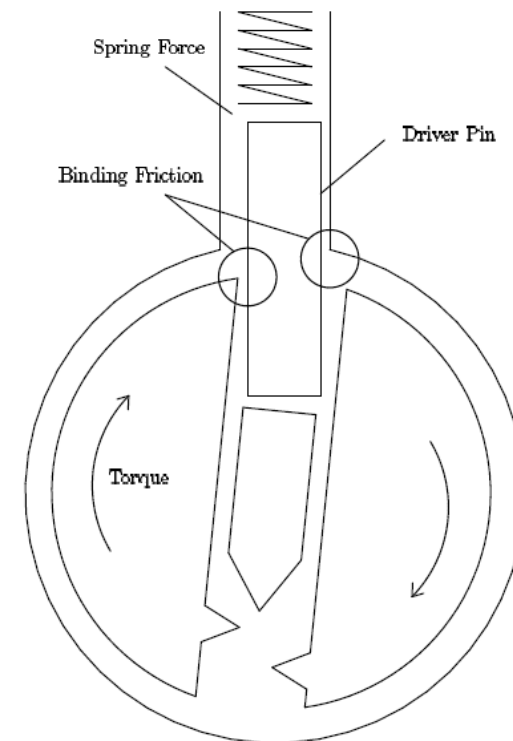

Figure 5.2: Binding in the pin-column model

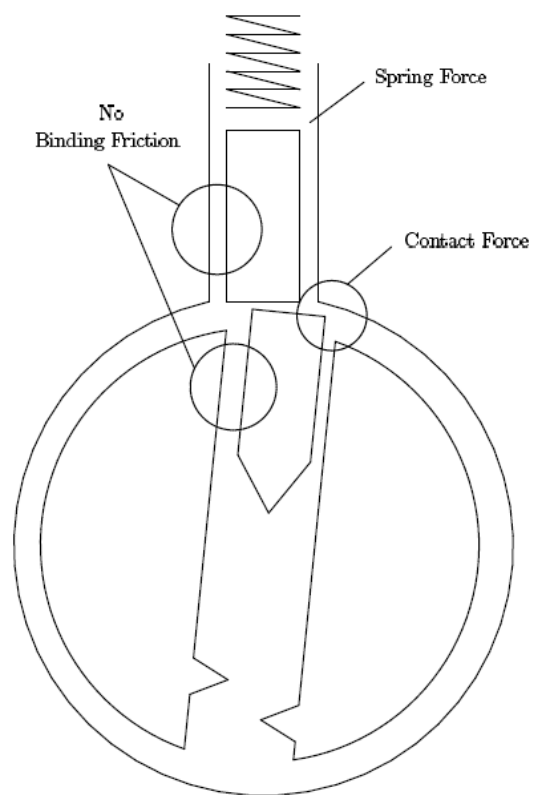

Figure 5.3: Pins at the shear line

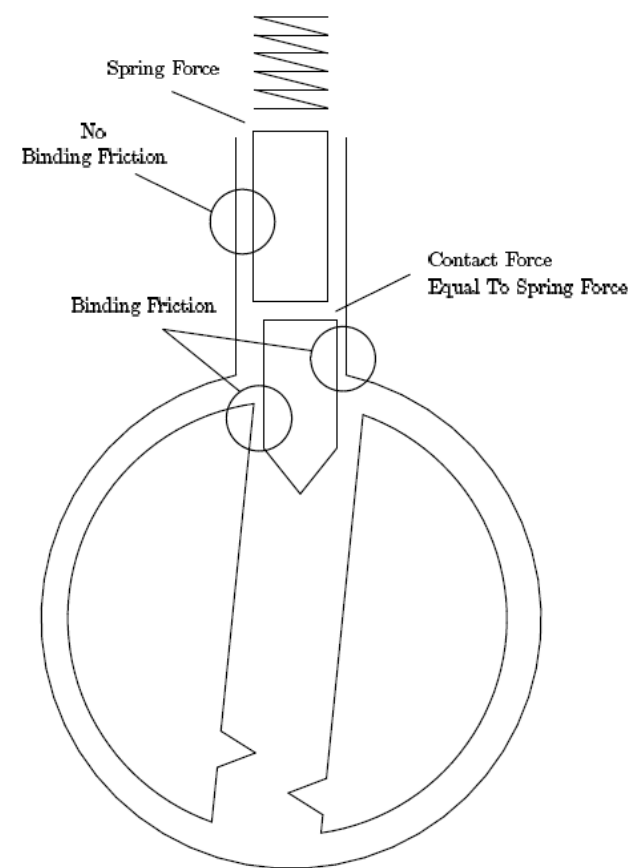

Figure 5.4: Key pin enters hull

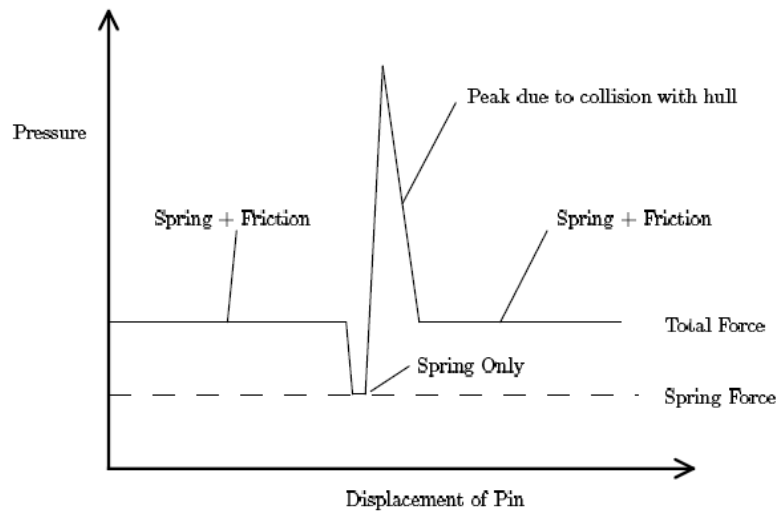

Figure 5.5: Pressure required to move pins

Chapter 6: Basic Scrubbing

At home you can take your time picking a lock, but in the field, speed is always essential. This chapter presents a lock picking technique called scrubbing that can quickly open most locks.

The slow step in basic picking (chapter 4) is locating the pin which is binding the most. The force diagram (Figure 5.5) developed in chapter 5 suggests a fast way to select the correct pin to lift. Assume that all the pins could be characterized by the same force diagram. That is, assume that they all bind at once and that they all encounter the same friction.

Now consider the effect of running the pick over all the pins with a pressure that is great enough to overcome the spring and friction forces but not great enough to overcome the collision force of the key pin hitting the hull. Any pressure that is above the portion of the force graph and below the top of the peak will work. As the pick passes over a pin, the pin will rise until it hits the hull, but it will not enter the hull. See Figure 5.3. The collision force at the shear line resists the pressure of the pick, so the pick rides over the pin without pressing it into the hull. If the proper torque is being applied, the plug will rotate slightly.

As the pick leaves the pin, the key pin will fall back to its initial position, but the driver pin will catch on the edge of the plug and stay above the shear line. See figure 6.1. In theory one stroke of the pick over the pins will cause the lock to open. In practice, at most one or two pins will set during a single stroke of the pick, so several strokes are necessary. Basically, you use the pick to scrub back and forth over the pins while you adjust the amount of torque on the plug. The exercises in chapter 8 will teach you how to choose the correct torque and pressure.

You will find that the pins of a lock tend to set in a particular order. Many factors effect this order (see chapter 9), but the primary cause is a misalignment between the centre axis of the plug and the axis on which the holes were drilled. See figure 6.2. If the axis of the pin holes is skewed from the centre line of the plug, then the pins will set from back to front if the plug is turned one way, and from front to back if the plug is turned the other way.

Many locks have this defect. Scrubbing is fast because you don't need to pay attention to individual pins. You only need to find the correct torque and pressure. Figure 6.1 summarizes the steps of picking a lock by scrubbing. The exercises will teach you how to recognize when a pin is set and how to apply the correct forces. If a lock doesn't open quickly, then it probably has one of the characteristics described in chapter 9 and you will have to concentrate on individual pins.

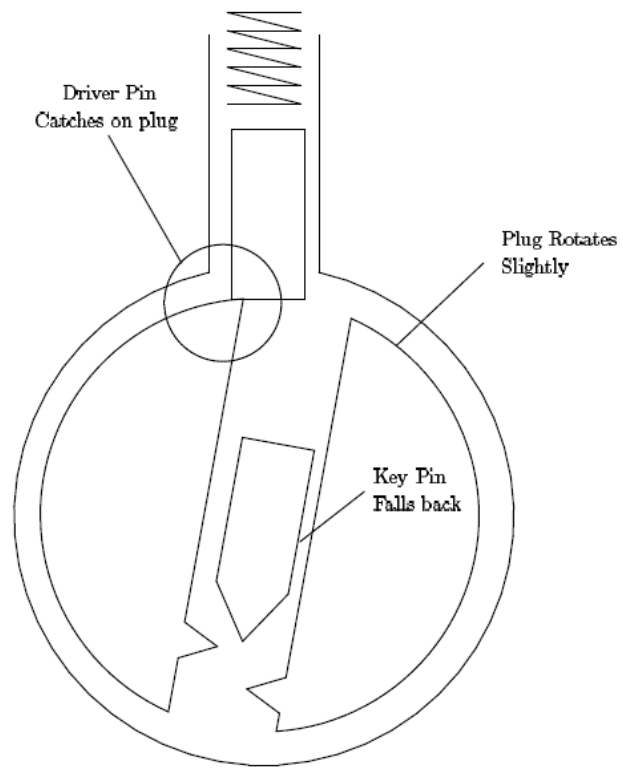

Figure 6.1: Driver pin catches on plug

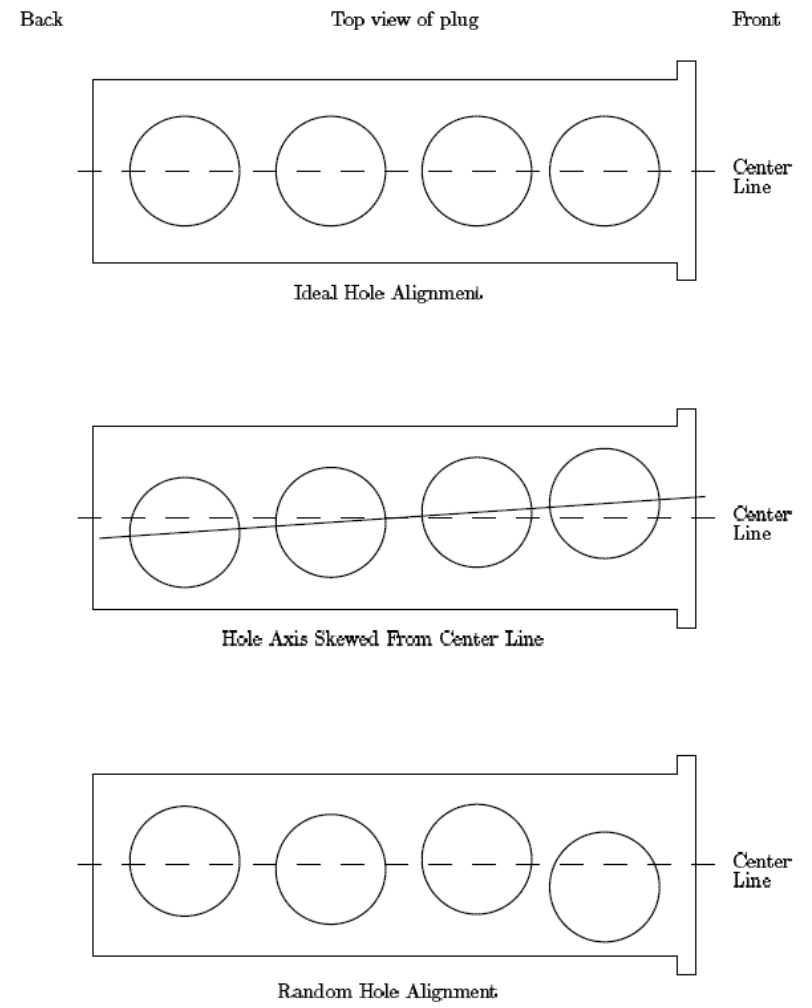

Figure 6.2: Alignment of plug holes

1. Insert the pick and torque wrench. Without applying any torque pull the pick out to get a feel for the stiffness of the lock's springs.
2. Apply a light torque. Insert the pick without touching the pins. As you pull the pick out, apply pressure to the pins. The pressure should be slightly larger than the minimum necessary to overcome the spring force.
3. Gradually increase the torque with each stroke of the pick until pins begin to set.
4. Keeping the torque fixed, scrub back and forth over the pins that have not set. If additional pins do not set, release the torque and start over with the torque found in the last step.
5. Once the majority of the pins have been set, increase the torque and scrub the Pins with a slightly larger pressure. This will set any pins which have set low due to bevelled edges, etc.

Table 6.1: Figure 13: Basic scrubbing.

Chapter 7: Advanced Lock Picking

Simple lock picking is a trade that anyone can learn. However, advanced lock picking is a craft that requires mechanical sensitivity, physical dexterity, visual concentration and analytic thinking. If you strive to excel at lock picking, you will grow in many ways.

7.1 Mechanical Skills

Learning how to pull the pick over the pins is surprisingly difficult. The problem is that the mechanical skills you learned early in life involved maintaining a fixed position or fixed path for your hands independent of the amount of force required. In lock picking, you must learn how to apply a fixed force independent of the position of your hand. As you pull the pick out of the lock you want to apply a fixed pressure on the pins. The pick should bounce up and down in the keyway according to the resistance offered by each pin.

To pick a lock you need feedback about the effects of your manipulations. To get the feedback, you must train yourself to be sensitive to the sound and feel of the pick passing over the pins. This is a mechanical skill that can only be learned with practice. The exercises will help you recognize the important information coming from your fingers.

7.2 Zen and the Art of Lock Picking

In order to excel at lock picking, you must train yourself to have a visually reconstructive imagination. The idea is to use information from all your senses to build a picture of what is happening inside the lock as you pick it. Basically, you want to project your senses into the lock to receive a full picture of how it is responding to your manipulations. Once you have learned how to build this picture, it is easy to choose manipulations that will open the lock.

All your senses provide information about the lock. Touch and sound provide the most information, but the other senses can reveal critical information. For example, your nose can tell you whether a lock has been lubricated recently. As a beginner, you will need to use your eyes for hand-eye coordination, but as you improve you will find it unnecessary to look at the lock. In fact, it is better to ignore your eyes and use your sight to build an image of the lock based on the information you receive from your fingers and ears.

The goal of this mental skill is to acquire a relaxed concentration on the lock. Don't force the concentration. Try to ignore the sensations and thoughts that are not related to the lock. Don't try to focus on the lock.

7.3 Analytic Thinking

Each lock has its own special characteristics which make picking harder or easier. If you learn to recognize and exploit the "personality traits" of locks, picking will go much faster. Basically, you want to analyze the feedback you get from a lock to diagnose its personality traits and then use your experience to decide on an approach to open the lock. Chapter 9 discusses a large number of common traits and ways to exploit or overcome them.

People underestimate the analytic skills involved in lock picking. They think that the picking tool opens the lock. To them the torque wrench is a passive tool that just puts the lock under the desired stress. Let me propose another way to view the situation. The pick is just running over the pins to get information about the lock. Based on an analysis that information the torque is adjusted to make the pins set at the sheer line. It's the torque wrench that opens the lock.

Varying the torque as the pick moves in and out of the keyway is a general trick that can be used to get around several picking problems. For example, if the middle pins are set, but the end pins are not, you can increase the torque as the pick moves over the middle pins. This will reduce the chances of disturbing the correctly set pins. If some pin doesn't seem to lift up far enough as the pick passes over it, then try reducing the torque on the next pass.

The skill of adjusting the torque while the pick is moving requires careful coordination between your hands, but as you become better at visualizing the process of picking a lock you will become better at this important skill.

Chapter 8: Exercises

This chapter presents a series of exercises that will help you learn the basic skill of lock picking. Some exercises teach a single skill, while others stress the coordination of skills.

When you do these exercises, focus on the skills, not on opening the lock. If you focus on opening the lock, you will get frustrated and your mind will stop learning. The goal of each exercise is to learn something about the particular lock you are holding and something about yourself. If a lock happens to open, focus on the memory of what you were doing and what you felt just before it opened.

These exercises should be practiced in short sessions. After about thirty minutes you will find that your fingers become sore and your mind loses its ability to achieve relaxed concentration.

8.1 Exercise 1: Bouncing the pick

This exercise helps you learn the skill of applying a fixed pressure with the pick independent of how the pick moves up and down in the lock. Basically you want to learn how to let the pick bounce up and down according to the resistance offered by each pin. How you hold the pick makes a difference on how easy it is to apply a fixed pressure.

You want to hold it in such a way that the pressure comes from your fingers or your wrist. Your elbow and shoulder do not have the dexterity required to pick locks. While you are scrubbing a lock, notice which of your joints are fixed, and which are allowed to move. The moving joints are providing the pressure.

One way to hold a pick is to use two fingers to provide a pivot point while another finger levers the pick to provide the pressure. Which fingers you use is a matter of personal choice. Another way to hold the pick is like holding a pencil. With this method, your wrist provides the pressure. If your wrist is providing the pressure, your shoulder and elbow should provide the force to move the pick in and out of the lock. Do not use your wrist to both move the pick and apply pressure.

A good way to get used to the feel of the pick bouncing up and down in the keyway is to try scrubbing over the pins of an open lock. The pins cannot be pushed down, so the pick must adjust to the heights of the pins. Try to feel the pins rattle as the pick moves over them. If you move the pick quickly, you can hear the rattle. This same rattling feel will help you recognize when a pin is set correctly. If a pin appears to be set but it doesn't rattle, then it is false set. False set pins can be fixed by pushing them down farther, or by releasing torque and letting them pop back to their initial position.

One last word of advice; focus on the tip of the pick. Don't think about how you are moving the handle; think about how you are moving the tip of the pick.

8.2 Exercise 2: Picking pressure

This exercise will teach you the range of pressures you will need to apply with a pick. When you are starting, just apply pressure when you are drawing the pick out of the lock. Once you have mastered that, try applying pressure when the pick is moving inward. With the flat side of your pick, push down on the first pin of a lock. Don't apply any torque to the lock.

The amount of pressure you are applying should be just enough to overcome the spring force. This force gives you an idea of minimum pressure you will apply with a pick. The spring force increases as you push the pin down. See if you can feel this increase. Now see how it feels to push down the other pins as you pull the pick out of the lock.

Start out with both the pick and torque wrench in the lock, but don't apply any torque. As you draw the pick out of the lock, apply enough pressure to push each pin all the way down. The pins should spring back as the pick goes past them. Notice the sound that the pins make as they spring back. Notice the popping feel as a pick goes past each pin. Notice the springy feel as the pick pushes down on each new pin.

To help you focus on these sensations, try counting the number of pins in the lock. Door locks at MIT have seven pins, padlocks usually have four.

To get an idea of the maximum pressure, use the flat side of your pick to push down all the pins in the lock. Sometimes you will need to apply this much pressure to a single pin. If you encounter a new kind of lock, perform this exercise to determine the stiffness of its springs.

8.3 Exercise 3: Picking Torque

This exercise will teach you the range of torque you will need to apply to a lock. It demonstrates the interaction between torque and pressure which was described in chapter 5.

The minimum torque you will use is just enough to overcome the friction of rotating the plug in the hull. Use your torque wrench to rotate the plug until it stops. Notice how much torque is needed to move the plug before the pins bind. This force can be quite high for locks that have been left out in the rain. The minimum torque for padlocks includes the force of a spring that is attached between the plug and the shackle bolt.

To get a feel for the maximum value of torque, use the flat side of the pick to push all the pins down, and try applying enough torque to make the pins stay down after the pick is removed. If your torque wrench has a twist in it, you may not be able to hold down more than a few pins.

If you use too much torque and too much pressure you can get into a situation like the one you just created. The key pins are pushed too far into the hull and the torque is sufficient to hold them there.

The range of picking torque can be found by gradually increasing the torque while scrubbing the pins with the pick. Some of the pins will become harder to push down. Gradually increase the torque until some of the pins set. These pins will lose their springiness. Keeping the torque fixed, use the pick to scrub the pins a few times to see if other pins will set.

The most common mistake of beginners is to use too much torque. Use this exercise to find the minimum torque required to pick the lock.

8.4 Exercise 4: Identifying Set Pins

While you are picking a lock, try to identify which pins are set. You can tell a pin is set because it will have a slight give. That is, the pin can be pushed down a short distance with a light pressure, but it becomes hard to move after that distance (see chapter 6 for an explanation). When you remove the light pressure, the pin springs back up slightly. Set pins also rattle if you flick them with the pick. Try listening for that sound.

Run the pick over the pins and try to decide whether the set pins are in the front or back of the lock (or both). Try identifying exactly which pins are set. Remember that pin one is the front-most pin (i.e., the pin that a key touches first). The most important skill of lock picking is the ability to recognize correctly set pins. This exercise will teach you that skill.

Try repeating this exercise with the plug turning in the other direction. If the front pins set when the plug is turned one way, the back pins will set when the plug is turned the other way. See Figure 6.2 for an explanation.

One way to verify how many pins are set is to release the torque, and count the clicks as the pins snap back to their initial position. Try this. Try to notice the difference in sound between the snap of a single pin and the snap of two pins at once. A pin that has been false set will also make a snapping sound.

Try this exercise with different amounts of torque and pressure. You should notice that a larger torque requires a larger pressure to make pins set correctly. If the pressure is too high, the pins will be jammed into the hull and stay there.

8.5 Exercise 5: Projection

As you are doing the exercises try building a picture in your mind of what is going on. The picture does not have to be visual, it could be a rough understanding of which pins are set and how much resistance you are encountering from each pin. One way to foster this picture building is to try to remember your sensations and beliefs about a lock just before it opened.

When a lock opens, don't think "that's over", think "what happened". This exercise requires a lock that you find easy to pick. It will help you refine the visual skills you need to master lock picking. Pick the lock, and try to remember how the process felt. Rehearse in your mind how everything feels when the lock is picked properly. Basically, you want to create a movie that records the process of picking the lock. Visualize the motion of your muscles as they apply the correct pressure and torque, and feel the resistance encountered by the pick. Now pick the lock again trying to match your actions to the movie.

By repeating this exercise, you are learning how to formulate detailed commands for your muscles and how to interpret feedback from your senses. The mental rehearsal teaches you how to build a visual understanding of the lock and how to recognize the major steps of picking it.

Chapter 9: Recognizing and Exploiting Personality Traits

Real locks have a wide range of mechanical features and defects that help and hinder lock picking. If a lock doesn't respond to scrubbing, then it probably has one of the traits discussed in this chapter. To open the lock, you must diagnose the trait and apply the recommended technique. The exercises will help you develop the mechanical sensitivity and dexterity necessary to recognize and exploit the different traits.

9.1 Which Way To Turn

It can be very frustrating to spend a long time picking a lock and then discover that you turned the plug the wrong way. If you turn a plug the wrong way it will rotate freely until it hits a stop, or until it rotates 180 degrees and the drivers enter the keyway (see section 9.11).

Section 9.11 also explains how to turn the plug more than 180 degrees if that is necessary to fully retract the bolt. When the plug is turned in the correct direction, you should feel an extra resistance when the plug cam engages the bolt spring.

The direction to turn the plug depends on the bolt mechanism, not on the lock, but here are some general rules. Cheap padlocks will open if the plug is turned in either direction, so you can choose the direction which is best for the torque wrench. All padlocks made by the Master Company can be opened in either direction. Padlocks made by Yale will only open if the plug is turned clockwise. The double plug Yale cylinder locks generally open by turning the bottom of the keyway (i.e., the flat edge of the key) away from the nearest doorframe.

Single plug cylinder locks also follow this rule. See Figure 9.1. Locks built into the doorknob usually open clockwise. Desk and filing cabinet locks also tend to open clockwise. When you encounter a new kind of lock mechanism, try turning the plug in both directions. In the correct direction, the plug will be stopped by the pins, so the stop will feel mushy when you use heavy torque. In the wrong direction the plug will be stopped by a metal tab, so the stop will feel solid.

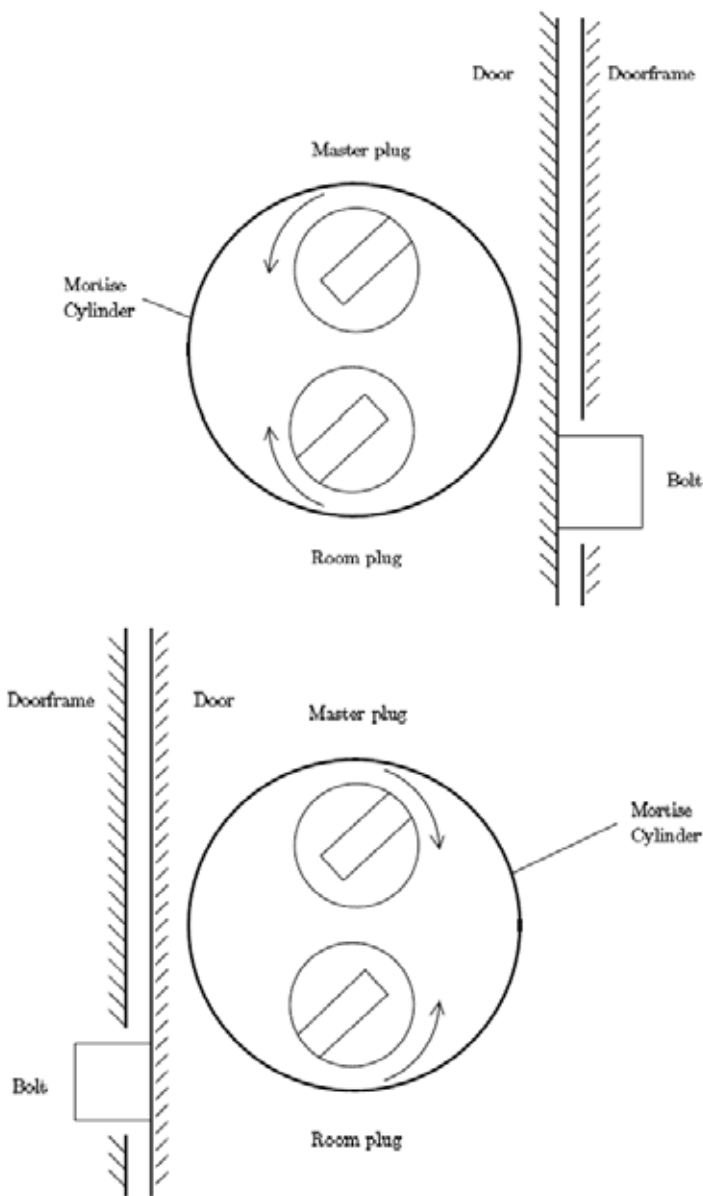

Figure 9.1: Direction to turn plug

9.2 How Far to Turn

The companion question to which way to turn a lock is how far to turn it. Desk and filing cabinet locks generally open with less than a quarter turn (90 degrees) of the plug. When opening a desk lock try to avoid having the plug lock in the open position. Locks built into doorknobs also tend to open with less than a quarter turn.

Locks which are separate from the doorknob tend to require a half turn to open. Deadbolt lock mechanisms can require almost a full turn to open.

Turning a lock more than 180 degrees is a difficult because the drivers enter the bottom of the keyway. See section 9.11.

9.3 Gravity

Picking a lock that has the springs at the top is different than picking one with the springs at the bottom. It should be obvious how to tell the two apart. The nice feature of a lock with the springs at the bottom is that gravity holds the key pins down once they set. With the set pins out of the way, it is easy to find and manipulate the remaining unset pins.

It is also straight forward to test for the slight give of a correctly set pin. When the springs are on top, gravity will pull the key pins down after the driver pin catches at the shear line. In this case, you can identify the set pins by noticing that the key pin is easy to lift and that it does not feel springy. Set pins also rattle as you draw the pick over them because they are not being pushed down by the driver pin.

9.4 Pins Not Setting

If you scrub a lock and pins are not setting even when you vary the torque, then some pin has false set and it is keeping the rest of the pins from setting. Consider a lock whose pins prefer to set from back to front. If the backmost pin false sets high or low (see *Figure 9.2*), then the plug cannot rotate enough to allow the other pins to bind.

It is hard to recognize that a back pin has false set because the springiness of the front pins makes it hard to sense the small give of a correctly set back pin. The main symptom of this situation is that the other pins will not set unless a very large torque is applied.

When you encounter this situation, release the torque and start over by concentrating on the back pins. Try a light torque and moderate pressure, or heavy torque and heavy pressure. Try to feel for the click that happens when a pin reaches the shear line and the plug rotates slightly. The click will be easier to feel if you use a stiff torque wrench.

9.5 Elastic Deformation

The interesting events of lock picking happen over distances measured in thousandths of an inch. Over such short distances, metals behave like springs. Very little force is necessary to detect a piece of metal over those distances, and when the force is removed, the metal will spring back to its original position.

Deformation can be used to your advantage if you want to force several pins to bind at once. For example, picking a lock with pins that prefer to set from front to back is slow because the pins set one at a time. This is particularly true if you only apply pressure as the pick is drawn out of the lock. Each pass of the pick will only set the front-most pin that is binding. Numerous passes are required to set all the pins. If the preference for setting is not very strong (i.e., the axis of the plug holes is only slightly skewed from the plug's centre line), then you can cause additional pins to bind by applying extra torque.

Basically, the torque puts a twist in the plug that causes the front of the plug to be detected further than the back of the plug. With light torque, the back of the plug stays in its initial position, but with medium to heavy torque, the front pin columns bend enough to allow the back of the plug to rotate and thus cause the back pins to bind. With the extra torque, a single stroke of the pick can set several pins, and the lock can be opened quickly. Too much torque causes its own problems.

When the torque is large, the front pins and plug holes can be deformed enough to prevent the pins from setting correctly. In particular, the first pin tends to false set low. *Figure 9.2* shows how excess torque can deform the bottom of the driver pin and prevent the key pin from reaching the shear line.

This situation can be recognized by the lack of give in the first pin. Correctly set pins feel springy if they are pressed down slightly. A falsely set pin lacks this springiness. The solution is to press down hard on the first pin. You may want to reduce the torque slightly, but if you reduce torque too much then other pins will unset as the first pin is being depressed. It is also possible to deform the top of the key pin. The key pin is scissored between the plug and the hull and stays fixed. When this happens, the pin is said to be false set high.

9.6 Loose Plug

The plug is held into the hull by being wider at the front and by having a cam on the back that is bigger than the hole drilled into the hull. If the cam is not properly installed, the plug can move in and out of the lock slightly. On the outward stroke of the pick, the plug will move forward, and if you apply pressure on the inward stroke, the plug will be pushed back. The problem with a loose plug is that the driver pins tend to set on the back of the plug holes rather than on the sides of the holes. When you push the plug in, the drivers will unset. You can use this defect to your advantage by only applying pressure on the outward or inward stroke of the pick. Alternatively, you can use your finger or torque wrench to prevent the plug from moving forward.

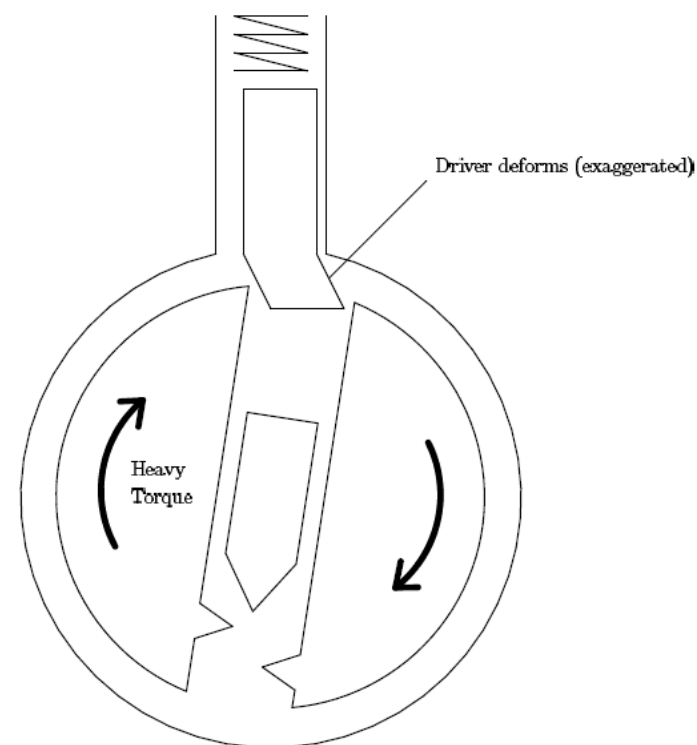

Figure 9.2: Driver pin false set by elastic deformation

9.7 Pin Diameter

When the pair of pins in a particular column have different diameters, that column will react strangely to the pressure of the pick.

The top half of *Figure 9.3* shows a pin column with a driver pin that has a larger diameter than the key pin. As the pins are lifted, the picking pressure is resisted by the binding friction and the spring force. Once the driver clears the sheer line, the plug rotates (until some other pin binds) and the only resistance to motion is the spring force.

If the key pin is small enough and the plug did not rotate very far, the key pin can enter the hull without colliding with the edge of the hull. Some other pin is binding, so again the only resistance to motion is the spring force. This relationship is graphed in the bottom half of the Figure. Basically, the pins feel normal at first, but then the lock clicks and the pin becomes springy.

The narrow key pin can be pushed all the way into the hull without losing its springiness, but when the picking pressure is released, the key pin will fall back to its initial position while the large driver catches on the edge of the plug hole.

The problem with a large driver pin is that the key pin tends to get stuck in the hull when some other pin sets. Imagine that a neighbouring pin sets and the plug rotates enough to bind the narrow key pin. If the pick was pressing down on the narrow key pin at the same time as it was pressing down on the pin that set, then the narrow key pin will be in the hull and it will get stuck there when the plug rotates.

The behaviour of a large key pin is left as an exercise for the reader.

9.8 Bevelled Holes and Rounded pins

Some lock manufacturers (e.g., Yale) bevel the edges of the plug holes and/or round off the ends of the key pins. This tends to reduce the wear on the lock and it can both help and hinder lock picking. You can recognize a lock with these features by the large give in set pins. See *Figure 9.4*. That is, the distance between the height at which the driver pin catches on the edge of the plug hole and the height at which the key pin hits the hull is larger (sometimes as large as a sixteenth of an inch) when the plug holes are bevelled or the pins are rounded.

While the key pin is moving between those two heights, the only resistance to motion will be the force of the spring. There won't be any binding friction. This corresponds to the dip in the force graph shown in *Figure 5.5*.

A lock with bevelled plug holes requires more scrubbing to open than a lock without bevelled holes because the driver pins set on the bevel instead of setting on the top of the plug. The plug will not turn if one of the drivers is caught on a bevel.

32

The key pin must be scrubbed again to push the driver pin up and off the bevel. The left driver pin in *Figure 9.6a* is set. The driver is resting on the bevel, and the bottom plate has moved enough to allow the right driver to bind. *Figure 9.6b* shows what happens after the right driver pin sets. The bottom plate slides further to the right and now the left driver pin is scissored between the bevel and the top plate.

It is caught on the bevel. To open the lock, the left driver pin must be pushed up above the bevel. Once that driver is free, the bottom plate can slide and the right driver may bind on its bevel.

If you encounter a lock with bevelled plug holes, and all the pins appear to be set but the lock is not opening, you should reduce torque and continue scrubbing over the pins. The reduced torque will make it easier to push the drivers off the bevels. If any pins unset when you reduce the torque, try increasing the torque and the picking pressure. The problem with increasing the force is that you may jam some key pins into the hull.

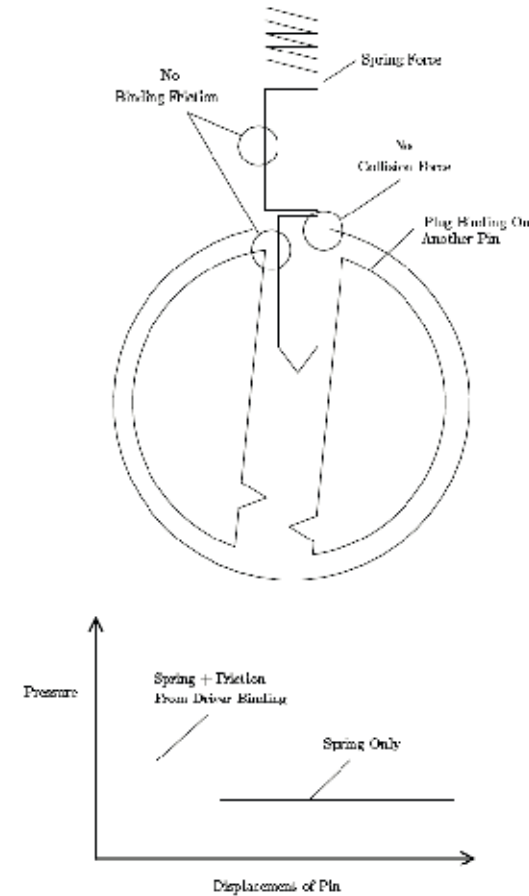

Figure 9.3: Driver pin wider than key pin

33

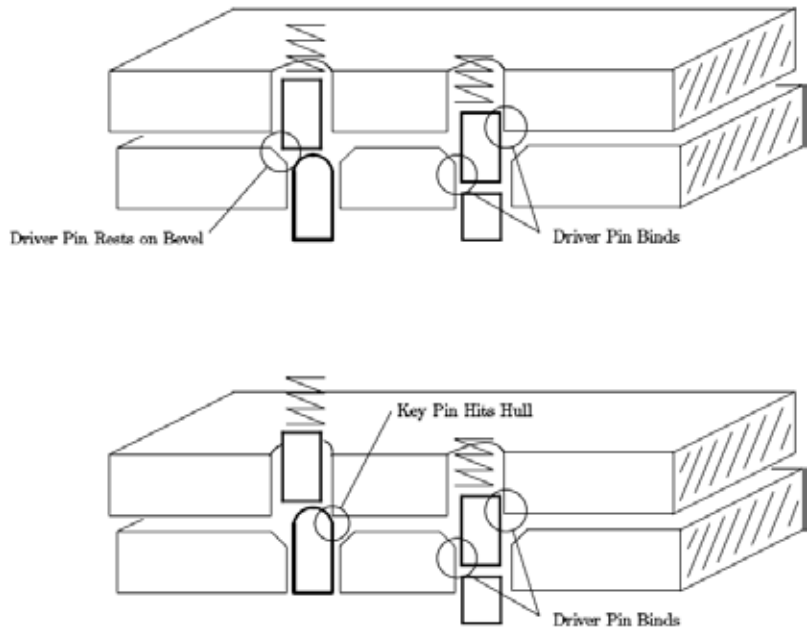

Figure 9.4: Bevelled plug holes and rounded key pins

9.9 Mushroom Driver Pins

A general trick that lock makers use to make picking harder is to modify the shape of the driver pin. The most popular shapes are mushroom, spool and serrated, see *Figure 9.7*. The purpose of these shapes is to cause the pins to false set low. These drivers stop a picking technique called vibration picking (see section 9.12), but they only slightly complicate scrubbing and one-pin-at-a-time picking (see chapter 4).

If you pick a lock and the plug stops turning after a few degrees and none of the pins can be pushed up any further, then you know that the lock has modified drivers. Basically, the lip of the driver has caught at the shear line. See the bottom of *Figure 9.7*. Mushroom and spool drivers are often found in Russwin locks, and locks that have several spacers for master keying.

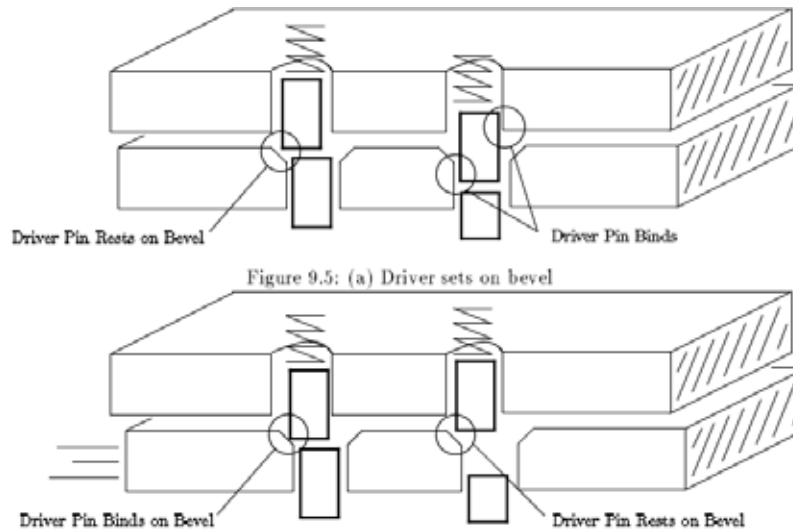

Figure 9.5: (a) Driver sets on bevel

Figure 9.6: Driver jams on bevel

You can identify the positions with mushroom drivers by applying a light torque and pushing up on each pin. The pins with mushroom drivers will exhibit a tendency to bring the plug back to the fully locked position. By pushing the key pin up you are pushing the top of the key pin against the tilted bottom of the mushroom driver. This causes the driver to straighten up which in turn causes the plug to unrotate.

You can use this motion to identify the columns that have mushroom drivers. Push those pins up to sheer line; even if you lose some of the other pins in the process they will be easier to re-pick than the pins with mushroom drivers. Eventually all the pins will be correctly set at the sheer line.

One way to identify all the positions with mushroom drivers is to use the flat of your pick to push all the pins up about halfway. This should put most of the drivers in their cockable position and you can feel for them.

To pick a lock with modified drivers, use a lighter torque and heavier pressure. You want to error on the side of pushing the key pins too far into the hull. In fact, another way to pick these locks is to use the flat side of your pick to push the pins up all the way, and apply very heavy torque to hold them there. Use a scrubbing action to vibrate the key pins while you slowly reduce the torque. Reducing the torque reduces the binding friction on the pins.

The vibration and spring force cause the key pins to slide down to the sheer line. The key to picking locks with modified drivers is recognizing incorrectly set pins. A mushroom driver set on its lip will not have the springy give of a correctly set driver. Practice recognizing the difference.

9.10 Master Keys

Many applications require keys that open only a single lock and keys that open a group of locks. The keys that open a single lock are called change keys and the keys that open multiple locks are called master keys. To allow both the change key and the master key to open the same lock, a locksmith adds an extra pin called a spacer to some of the pin columns. See *Figure 9.8*. The effect of the spacer is to create two gaps in the pin column that could be lined up with the sheer line.

Usually the change key aligns the top of the spacer with the sheer line, and the master key aligns the bottom of the spacer with the sheer line (the idea is to prevent people from filing down a change key to get a master key). In either case the plug is free to rotate.

In general, spacers make a lock easier to pick. They increase the number of opportunities to set each pin, and they make it more likely that the lock can be opened by setting all the pins at about the same height. In most cases only two or three positions will have spacers. You can recognize a position with a spacer by the two clicks you feel when the pin is pushed down.

If the spacer has a smaller diameter than the driver and key pins, then you will feel a wide springy region because the spacer will not bind as it passes through the sheer line. It is more common for the spacer to be larger than the driver pin.

You can recognize this by an increase in friction when the spacer passes through the sheer line. Since the spacer is larger than the driver pin, it will also catch better on the plug. If you push the spacer further into the hull, you will feel a strong click when the bottom of the spacer clears the sheer line.

Thin spacers can cause serious problems. If you apply heavy torque and the plug has bevelled holes, the spacer can twist and jam at the sheer line. It is also possible for the spacer to fall into the keyway if the plug is rotated 180 degrees. See section 9.11 for the solution to this problem.

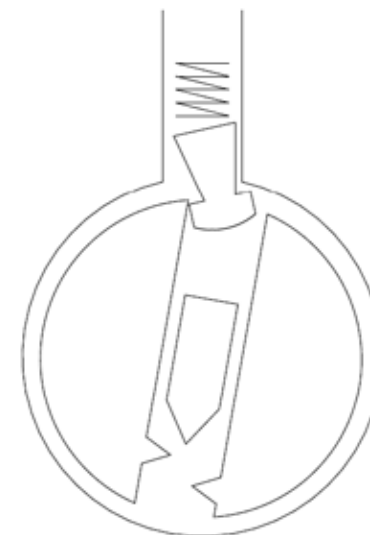
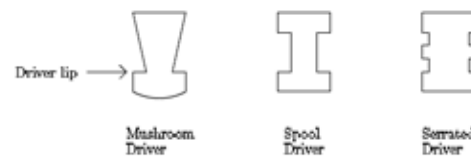

Figure 9.7: Mushroom, spool and serrated driver pins

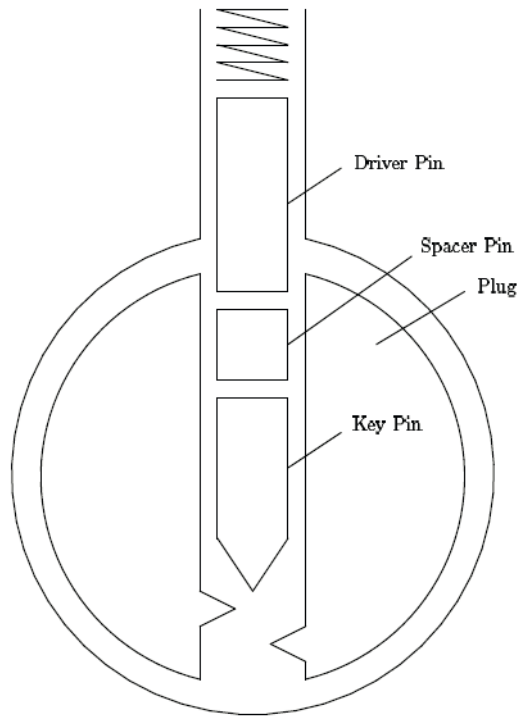

Figure 9.8: Spacer pins for master keying

9.11 Driver or Spacer Enters Keyway

Figure 9.9 shows how a spacer or driver pin can enter the keyway when the plug is rotated 180 degrees. You can prevent this by placing the side of your pick in the bottom of the keyway before you turn the plug too far. If a spacer or driver does enter the keyway and prevent you from turning the plug, use the side of your pick to push the spacer back into the hull. You may need to use the torque wrench to relieve any sheer force that is binding the spacer or driver. If that doesn't work try raking over the drivers with the pointed side of your pick. If a spacer falls into the keyway completely, the only option is to remove it. A hook shaped piece of spring steel works well for this, though a bent paperclip will work just as well unless the spacer becomes wedged.

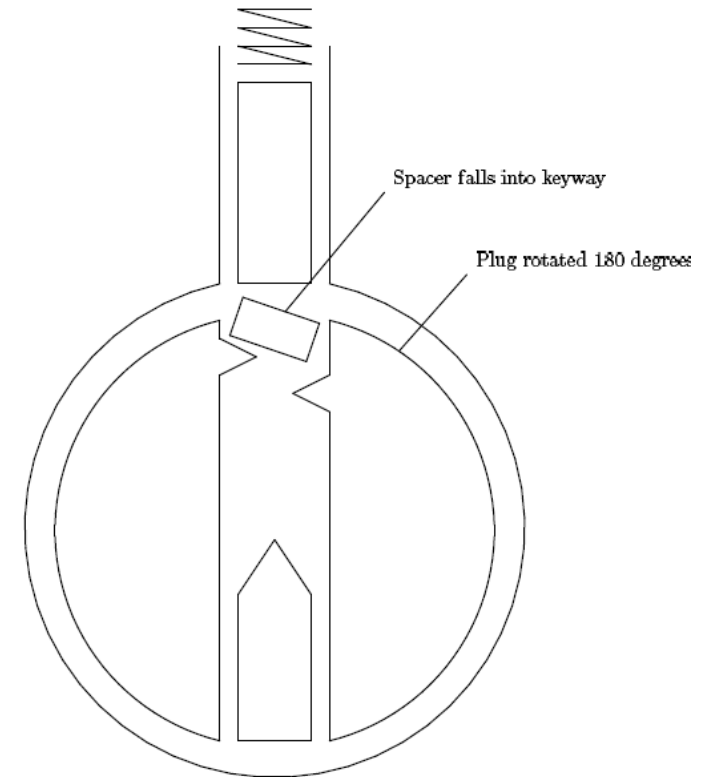

Figure 9.9: Spacer or driver can enter keyway

9.12 Vibration Picking

Vibration picking works by creating a large gap between the key and driver pins. The underlying principle is familiar to anyone who has played pool. When the queue ball strikes another ball squarely, the queue ball stops and the other ball heads off with the same speed and direction as the queue ball. Now imagine a device that kicks the tips of all the key pins.

The key pins would transfer their momentum to the driver pins which would y up into the hull. If you are applying a light torque when this happens, the plug will rotate when all the drivers are above the sheer line.

9.13 Disk Tumblers

The inexpensive locks found on desks use metal disks instead of pins. Figure 9.10 shows the basic workings of these locks. The disks have the same outline but differ in the placement of the rectangular cut.

These locks are easy to pick with the right tools. Because the disks are placed close together a half-round pick works better than a half-diamond pick (see Figure A.1). You may also need a torque wrench with a narrower head. Use moderate to heavy torque.

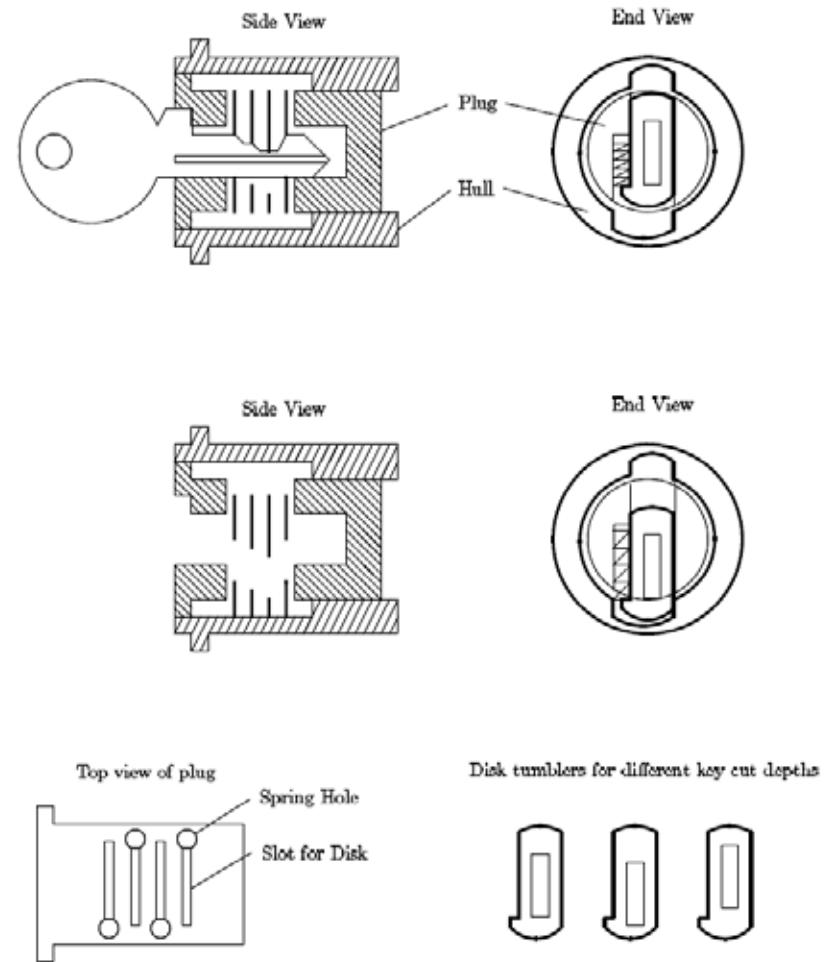

Figure 9.10: Workings of a disk tumbler lock

Chapter 10: Final Remarks

Lock picking is a craft, not a science. This document presents the knowledge and skills that are essential to lock picking, but more importantly it provides you with models and exercises that will help you study locks on your own.

To excel at lock picking, you must practice and develop a style which fits you personally. Remember that the best technique is the one that works best for you.

Appendix A: Tools

This appendix describes the design and construction of lock picking tools.

A.1 Pick Shapes

Picks come in several shapes and sizes. *Figure A.1* shows the most common shapes. The handle and tang of a pick are the same for all picks. The handle must be comfortable and the tang must be thin enough to avoid bumping pins unnecessarily. If the tang is too thin, then it will act like a spring and you will lose the feel of the tip interacting with the pins. The shape of the tip determines how easily the pick passes over the pins and what kind of feedback you get from each pin.

The design of a tip is a compromise between ease of insertion, ease of withdrawal and feel of the interaction. The half diamond tip with shallow angles is easy to insert and remove, so you can apply pressure when the pick is moving in either direction. It can quickly pick a lock that has little variation in the lengths of the key pins. If the lock requires a key that has a deep cut between two shallow cuts, the pick may not be able to push the middle pin down far enough. The half diamond pick with steep angles could deal with such a lock, and in general steep angles give you better feedback about the pins. Unfortunately, the steep angles make it harder to move the pick in the lock. A tip that has a shallow front angle and a steep back angle works well for Yale locks.

The half round tip works well in disk tumbler locks. See section 9.13. The full diamond and full round tips are useful for locks that have pins at the top and bottom of the keyway.

The rake tip is designed for picking pins one by one. It can also be used to rake over the pins, but the pressure can only be applied as the pick is withdrawn. The rake tip allows you to carefully feel each pin and apply varying amounts of pressure. Some rake tips are flat or dented on the top to make it easier to align the pick on the pin. The primary benefit of picking pins one at a time is that you avoid scratching the pins. Scrubbing scratches the tips of the pins and the keyway, and it spreads metal dust throughout the lock. If you want to avoid leaving traces, you must avoid scrubbing.

The snake tip can be used for scrubbing or picking. When scrubbing, the multiple bumps generate more action than a regular pick. The snake tip is particularly good at opening five pin household locks. When a snake tip is used for picking, it can set two or three pins at once. Basically, the snake pick acts like a segment of a key which can be adjusted by lifting and lowering the tip, by tilting it back and forth, and by using either the top or bottom of the tip. You should use moderate to heavy torque with a snake pick to allow several pins to bind at the same time. This style of picking is faster than using a rake and it leaves as little evidence.

A.2 Street cleaner bristles

The spring steel bristles used on street cleaners make excellent tools for lock picking. The bristles have the right thickness and width, and they are easy to grind into the desired shape. The resulting tools are springy and strong. Section A.3 describes how to make tools that are less springy.

The first step in making tools is to sand off any rust on the bristles. Course grit sand paper works fine as does a steel wool cleaning pad (not copper wool). If the edges or tip of the bristle are worn down, use a file to make them square.

A torque wrench has a head and a handle as shown in *Figure A.2*. The head is usually 1/2 to 3/4 of an inch long and the handle varies from 2 to 4 inches long. The head and the handle are separated by a bend that is about 80 degrees. The head must be long enough to reach over any protrusions (such as a grip-proof collar) and firmly engage the plug. A long handle allows delicate control over the torque, but if it is too long, it will bump against the doorframe.

The handle, head and bend angle can be made quite small if you want to make tools that are easy to conceal (e.g., in a pen, flashlight, or belt buckle). Some torque wrenches have a 90 degree twist in the handle. The twist makes it easy to control the torque by controlling how far the handle has been deflected from its rest position. The handle acts as a spring which sets the torque. The disadvantage of this method of setting the torque is that you get less feedback about the rotation of the plug. To pick difficult locks you will need to learn how to apply a steady torque via a stiff handled torque wrench.

The width of the head of a torque wrench determines how well it will fit the keyway. Locks with narrow keyways (e.g., desk locks) need torque wrenches with narrow heads. Before bending the bristle, file the head to the desired width. A general purpose wrench can be made by narrowing the tip (about 1/4 inch) of the head. The tip fits small keyways while the rest of the head is wide enough to grab a normal keyway.

The hard part of making a torque wrench is bending the bristle without cracking it. To make the 90 degree handle twist, clamp the head of the bristle (about one inch) in a vise and use pliers to grasp the bristle about 3/8 of an inch above the vise. You can use another pair of pliers instead of a vise. Apply a 45 degree twist. Try to keep the axis of the twist lined up with the axis of the bristle. Now move the pliers back another 3/8 inch and apply the remaining 45 degrees. You will need to twist the bristle more than 90 degrees in order to set a permanent 90 degree twist.

To make the 80 degree head bend, lift the bristle out of the vise by about 1/4 inch (so 3/4 inch is still in the vise). Place the shank of a screw driver against the bristle and bend the spring steel around it about 90 degrees. This should set a permanent 80 degree bend in the metal. Try to keep the axis of the bend perpendicular to the handle. The screwdriver shank ensures that the radius of curvature will not be too small.

Any rounded object will work (e.g., drill bit, needle nose pliers, or a pen cap). If you have trouble with this method, try grasping the bristle with two pliers separated by about 1/2 inch and bend. This method produces a gentle curve that won't break the bristle.

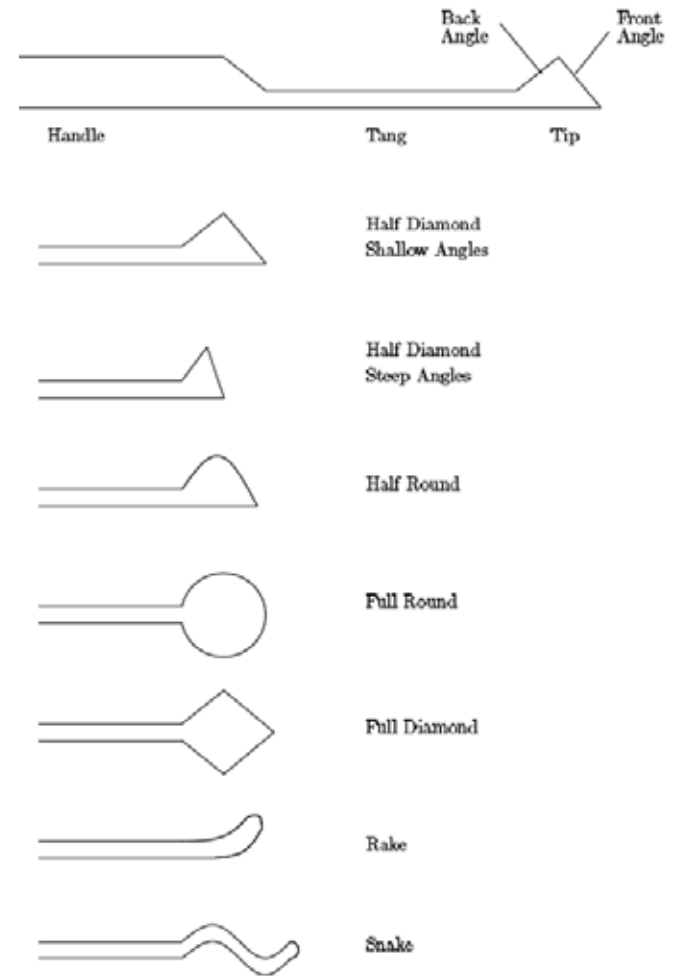

Figure A.1: Selection of pick shapes

A grinding wheel will greatly speed the job of making a pick. It takes a bit of practice to learn how to make smooth cuts with a grinding wheel, but it takes less time to practice and make two or three picks than it does to hand file a single pick. The first step is to cut the front angle of the pick. Use the front of the wheel to do this. Hold the bristle at 45 degrees to the wheel and move the bristle side to side as you grind away the metal. Grind slowly to avoid overheating the metal, which makes it brittle. If the metal changes colour (to dark blue), you have overheated it, and you should grind away the coloured portion.

Next, cut the back angle of the tip using the corner of the wheel. Usually one corner is sharper than the other, and you should use that one. Hold the pick at the desired angle and slowly push it into the corner of the wheel. The side of the stone should cut the back angle. Be sure that the tip of the pick is supported. If the grinding wheel stage is not close enough to the wheel to support the tip, use needle nose pliers to hold the tip. The cut should pass through about 2/3 of the width of the bristle. If the tip came out well, continue. Otherwise break it off and try again.

You can break the bristle by clamping it into a vise and bending it sharply. The corner of the wheel is also used to grind the tang of the pick. Put a scratch mark to indicate how far back the tang should go. The tang should be long enough to allow the tip to pass over the back pin of a seven pin lock. Cut the tang by making several smooth passes over the corner. Each pass starts at the tip and moves to the scratch mark.

Try to remove less than a 1/16th of an inch of metal with each pass. I use two fingers to hold the bristle on the stage at the proper angle while my other hand pushes the handle of the pick to move the tang along the corner. Use whatever technique works best for you. Use a hand file to finish the pick. It should feel smooth if you run a finger nail over it. Any roughness will add noise to the feedback you want to get from the lock. The outer sheath of phone cable can be used as a handle for the pick. Remove three or four of the wires from a length of cable and push it over the pick. If the sheath won't stay in place, you can put some epoxy on the handle before pushing the sheath over it.

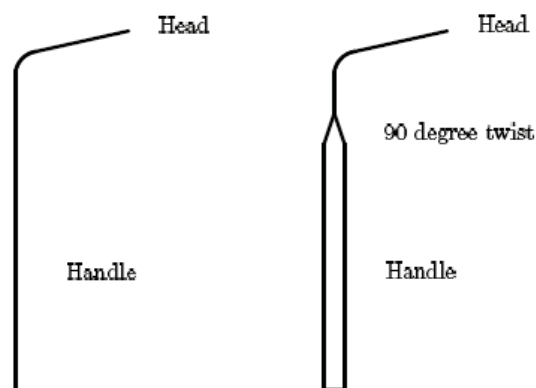

Figure A.2: Torque wrenches

A.3 Bicycle spokes

An alternative to making tools out of street cleaner bristles is to make them out of nails and bicycle spokes. These materials are easily accessible and when they are heat treated, they will be stronger than tools made from bristles.

A strong torque wrench can be constructed from an 8-penny nail (about .1 inch diameter). First heat up the point with a propane torch until it glows red, slowly remove it from the flame, and let it air cool; this softens it. The burner of a gas stove can be used instead of a torch. Grind it down into the shape of a skinny screwdriver blade and bend it to about 80 degrees. The bend should be less than a right angle because some lock faces are recessed behind a plate (called an escutcheon) and you want the head of the wrench to be able to reach about half an inch into the plug. Temper (harden) the torque wrench by heating to bright orange and dunking it into ice water. You will wind up with a virtually indestructible bent screwdriver that will last for years under brutal use.

Bicycle spokes make excellent picks. Bend one to the shape you want and file the sides of the business end at such that it's strong in the vertical and flexy in the horizontal direction. Try a right-angle hunk about an inch long for a handle. For smaller picks, which you need for those really tiny keyways, find any large-diameter spring and unbend it. If you're careful you don't have to play any metallurgical games.

A.4 Brick Strap

For perfectly serviceable key blanks that you can't otherwise find at the store, use the metal strap they wrap around bricks for shipping. It's wonderfully handy stuff for just about anything you want to manufacture. To get around side wards in the keyway, you can bend the strap lengthwise by clamping it in a vice and tapping on the protruding part to bend the piece to the required angle.

Brick strap is very hard. It can ruin a grinding wheel or key cutting machine. A hand file is the recommended tool for milling brick strap.

Appendix B: Legal Issues

Contrary to widespread myth, it is not a felony to possess lockpicks. Each state has its own laws with respect to such burglarious instruments. Here is the Massachusetts version quoted in entirety from the Massachusetts general code:

Chapter 266 (crimes against property) Section 49

Burglarious instruments; making; possession; use. Whoever makes or mends, or begins to make or mend, or knowingly has in his possession, an engine, machine, tool or implement adapted and designed for cutting through, forcing or breaking open a building, room, vault, safe or other depository, IN ORDER TO STEAL THEREFROM money or other property, or to commit any other crime, knowing the same to be adapted and designed for the purpose aforesaid, WITH INTENT TO USE OR EMPLOY OR ALLOW the same to be used or employed for such purpose, or whoever knowingly has in his possession a master key designed to fit more than one motor vehicle, WITH INTENT, TO USE OR EMPLOY THE SAME to steal a motor vehicle or other property there from, shall be punished by imprisonment in the state prison for not more than ten years or by a fine of not more than one thousand dollars and imprisonment in jail for not more than two and one half years.

Emphasis added. In other words, mere possession means nothing. If they stop you for speeding or something, and find a pick set, they can't do much. On the other hand, if they catch you picking the lock on a Monec machine they get to draw and quarter you. States with similar wording include ME, NH, NY. One place that DOES NOT have similar wording, and does make possession illegal, is Washington, DC. These are the only other places I have checked. I would imagine that most states are similar to Massachusetts, but I would not bet anything substantial (say, more than a slice of pizza) on it.

It may be a good idea to carry around a Xeroxed copy of the appropriate page from your state's criminal code.

Improvised Lock Picks

(Formerly titled : POLICE GUIDE TO LOCK PICKING)

FOREWORD

From regular law enforcement to security guards - from gun shop owners to alarm installers - all are expected to know the answers to the general public's questions about physical security.

With all that has been published in the last few security conscious years most everyone knows the virtues of a dead-bolt latch versus a spring bolt latch; the vulnerability of a sliding arcadia door, casement windows, and exposed hinge pins; the need for security chains & peep holes on front doors, etc.

Most all people concerned are well advised and knowledgeable in most of these "standard" areas of physical security. However, the subject of "lockpicking", "lockpicks", and "pickproof locks" affords a large grey area of confusion and misinformation.

Misled by TV detective & spy shows, where the hero or villain as the case may be is able to pick his way, usually with only one hand, through about any "locked in" or "locked out" situation and also by manufacturers seeking to promote their latest "pickproof cylinder", the average person is prone to consider "lockpicking" as a standard *modus operandi* for any would be burglar.

The purpose of this book is to shed light on the subject of lockpicking and better equip the reader to make the proper decisions concerning physical security. There will be those who will consider publishing this book as a contribution to the training of potential criminals. Those so naive may rest assured that any among us possessing larcenous intent already know this subject well, if lockpicking happens to be a needed skill.

Basic lock design

Before a general study of lockpicking can be made the basics of lock design should be considered. Let us first think in terms of what a lock is and how it achieves its purpose. Basically, a lock is a latch intended on holding the object to which it is attached in a certain position. A simple gate latch is, by definition, a lock. It does not require a key, only the knowledge and dexterity to perform a simple movement. Fortunately, for the farmer, cattle and other farm animals do not normally possess this knowledge and dexterity. We say "normally possess" because- occasionally an animal will learn to manipulate or "pick" a gate or door open. In effect, this animal is a "lockpicker", the pick being that part of their anatomy used to open the latch.

We are purposely boring you with this Aesop's fable to align our thinking about lock design and consequently lock picking methods.

Early lock design was hardly more than a simple latch operated by either a device (key) or knowledge (combination, secret keyway, etc.) possessed, hopefully, by only those with rightful access to the contents beyond.

But man, being a clever sort, was soon able to devise ways of opening these locks without a key. This, of course, prompted other "clever sorts" to design more "pick-resistant" devices. Most common designs required a device (key) to be inserted and rotated. Further refinements introduced special shaped keyholes, receiving only keys of similar profile.

Other refinements were internal structures known as "wards" that required matching cuts on the key before the key would turn after being inserted. This basic design is still prevalent today in low security locks as found in some luggage, cases, cupboards, cheap lock boxes, and padlocks. They, as a group, are known as "warded locks".

Little revolutionary design came about until the 1850's when Linus Yale, Sr. invented the now universally used pin tumbler lock. Until this time lock designers seemed to focus more attention to the ornate exterior than to the internal mechanism.

Yale's design was not as revolutionary as it was a mechanically sound adaption of earlier Egyptian design principles. It combined both high security and ease of manufacture. Ease of manufacture lends to mass production which yields relative low cost to the consumer. Until Yale's invention, high security locks were usually handmade by some locksmith at a much higher cost and even these reflected more attention to the exterior ornamentation than to the internal mechanism. This basic pin tumbler design is found today in millions of locks. Even some of the "pick-proof" designs are adaptations of this earlier design.

Economics are always a controlling factor where physical security is concerned. Economics affords us with material possessions. Sometimes for economic reasons, other people want to relieve us of those possessions. For economic reasons manufacturers provide us with devices to protect our possessions. Lock manufacturers make locks for one basic reason - to make money for the owner or stockholders of the company. Fighting crime is nice but it is so much nicer to make money while doing it.

Lock making is now a highly competitive business which requires thousands if not millions of dollars of investment in mass production equipment and tooling. Lock product marketing is quick to capitalize on consumer attitudes and try to "get there first" with what will sell the best.

In today's security conscious market place we are being deluged with security products, many of questionable value. Other products, while useful, should have been "standard equipment" on our homes or buildings when we bought them new. The author is opposed to laws, permits, codes and other bureaucratic trappings; however, still believes that an informed buying public should demand that builders do better.

In the last few years this "security consciousness" has inspired manufacturers to produce or market "pick resistant" locks and cylinders. Most manufacturers are careful to avoid using the term "pick proof" because this is an absolute term and leaves them no way out should someone succeed in picking their lock. We will take a closer look at some of these pick resistant" locks later in this book.

As a closing thought on basic lock design we should examine the purpose of a lock as part of a physical security system. No lock, even the "high security" versions will absolutely prevent access to the secure area. A lock can only provide two basic functions: make the potential intruder expend time and make noise. The more of either or both, the better the lock. Also, remember that a security system, like a chain, is no better than the weakest link.

LOCKPICKING

Definition of "Lockpicking" - The means of opening a lock mechanism by the intrusion of a tool or mechanical device, other than the normal operating key. This tool can be as simple as a bent paper clip or an expensive pick set or pick gun.

Why Locks Can Be Picked - A lock mechanism becomes vulnerable to picking for two basic reasons: design shortcomings and manufacturing shortcomings. Both of these flaws are directly related to the selling price of the locking device. The design flaw allows a pick, wire, pick key, paper clip, hair pin, knife blade, etc. to be inserted into the keyway in such a manner as to reach and operate the mechanism. Manufacturing shortcomings are found in loose tolerances in the manufacturing process. A tolerance is a necessary sloppiness that is found even in the most expensive of machine products. For example: an .250 in. diameter hole will seldom if ever be exactly .250. The closer to perfection the higher the cost. Therefore, whether in a lock or an automobile, a compromise must be arrived at the engineering level. Basically, an engineer will strive to make the part as cheap as possible and as precise as possible. In lock design a third requirement becomes more important than in some other products and that is strength and durability.

The vulnerability of tolerance is usually found in areas such as pin diameters versus pin hole diameters and a row of pin holes deviating from a straight line. Tolerances allow shims to be inserted in the small space necessary between moving parts. Tolerances allow a combination lock to reveal its inner secrets to a skilled manipulator. Tolerances, like the air around us are ever present in any machined product. They cannot be eliminated, only minimized which directly affects the cost of the part. By this time, if you are still reading this book, you may have come to the conclusion that lockpicking is a highly skilled technical complicated operation requiring mechanical savoy and dexterity beyond the majority of Joe Blows. If you have, then you are on the purpose of this book which is to show how difficult picking really is and why the average four thumbed, knuckle dragging, larcenous klutz does well to open a lock with the proper key

let alone pick it. A good pick man is about as rare as a good counterfeit plate engraver.

METHODS OF PICKING

Simple Warded Locks - These are typically found in cheaper padlocks, file boxes, luggage, etc. The keys are usually stamped from flat steel and nickel plated. Higher quality warded locks sometimes use corrugated keys in an effort to provide better security and also make the key stronger. Three such padlocks are shown in Figure 1. Their respective keys are also shown. A closer look will reveal that each key has the ward cuts in a slightly different position.

Internally, the mechanism is basically as shown in Figure 2. In this illustration we see a flat, hairpin type spring that latches into notches in the shackle. Only a portion, usually the tip of the key actuates the spring latch. Turning the key spreads the spring latch apart, releasing the shackle. It is easy to see that a pick for this simple design would only have to be a paper clip or wire with a small "L" bent on one end.

A pick key shaped as shown in Figure 3 would also operate any such lock whose keyway would accept it. This is simply a key with all the ward cuts opened up, leaving only the portion on the tip that is necessary to operate the latch spring.

Manufacturers, in an effort to improve the security of this basic locking mechanism, have now added another spring latch with a ward between them. This design complicates efforts to pick it with a bent wire as previously done. However, a double headed pick key will do the job. Such a key is shown in Figure 4. This key will operate all three locks pictured in Figure 1. Manufactured pick key sets such as shown in Figure 5 are commercially available to locksmiths and law enforcement agencies.

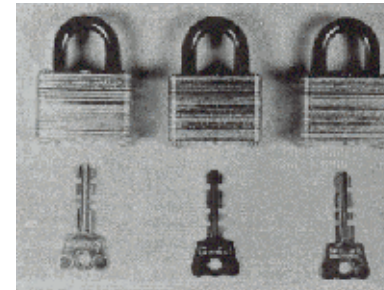

Fig. 1

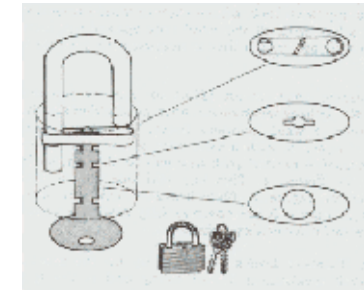

Fig. 2

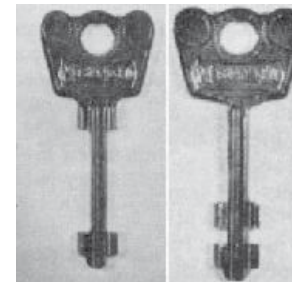

Fig. 3

Fig. 4

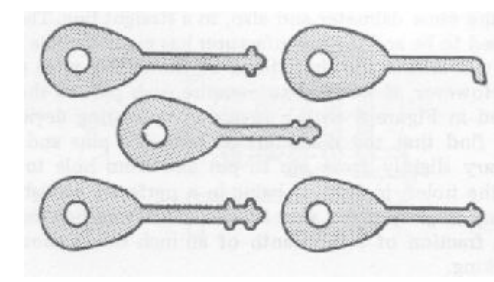

Fig. 5

Pin Tumbler Locks : This is by far the most common type lock mechanism found today and is the type which applies to the picking most commonly referred to in articles on security, and distorted on TV.

To understand picking this lock we must be familiar, to a limited degree, with its mechanism. Manufacturers have dozens of versions of this mechanism yet they are all basically the same mechanically. The drawings in Figures 6 and 7, and also the picture in Figure 8, show a basic mechanism. While they can

have more or less, the average pin tumbler lock has five sets of tumbler pins consisting of a spring, top pin, and bottom pin. The springs and top pins are usually the same length. The bottom pins vary in length to match the depth of the cuts in the key. When a key is inserted into the lock plug this set of pins is raised, compressing the spring. If the proper key has been inserted the bottom pins are all raised until they are flush with the diameter of the plug. This is also known as the shear line. At this point the plug is free to turn and release or activate whatever mechanism it is attached to.

To pick this mechanism we must somehow raise these pins or manipulate them so as to allow the plug to turn. Most methods of picking this lock rely on the presence of tolerances as we discussed earlier. In observing the picture and drawings previously mentioned, the tumbler pin holes seem to be the same diameter and also, in a straight line. They are supposed to be and the manufacturer has made a noble effort to do this within the limitations of the selling price of the lock. However, if we were to measure each part of the lock pictured in Figure 8 with a precision measuring device, we would find that the diameters of both the pins and holes may vary slightly from pin to pin and from hole to hole. Also, the holes, instead of being in a perfectly straight line will vary slightly from side to side. This variation may be only a fraction of a thousandth of an inch but is enough to aid picking.

Picking, in the purest sense, involves applying a very small turning force or torque to the plug and with a feeler pick, carefully probe each bottom pin to find the one or more that seem to be binding more than the rest. With the feeler pick, slowly lift one of these until the top pin clears the shear line.

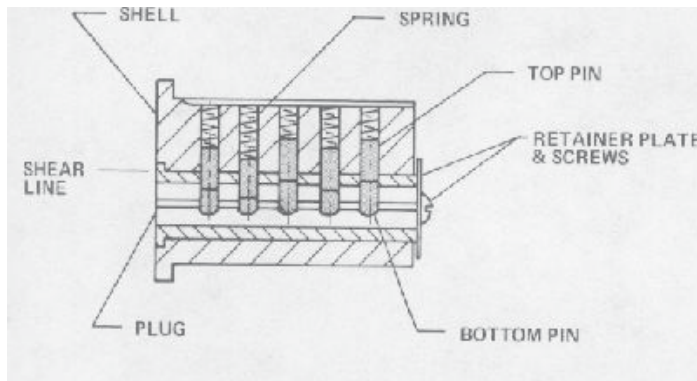

fig 6

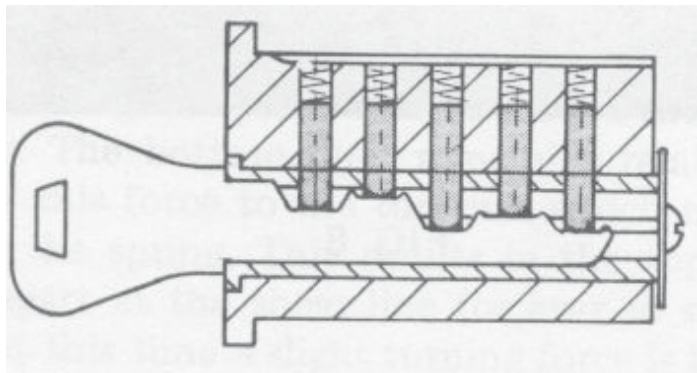

fig 7

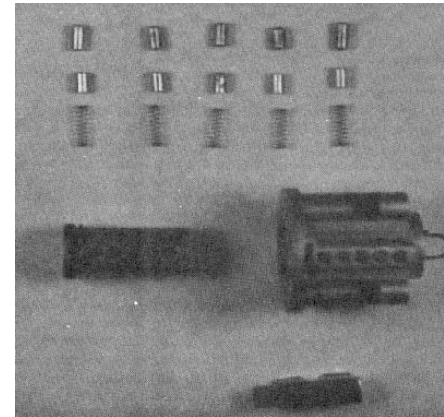

fig 8

At this time the plug may give slightly in the direction that torque is being applied. This operation is repeated on the remaining pins, at which time the plug will be free to turn.

Raking is another method of picking, perhaps the most often used because less skill is required as the lock opens more by chance than by skill. A rake tool has two or three up and down areas and is used in an in and out and up and down motion. The shape together with the random motion may at some unknown moment raise the bottom pins to the right level. If a small torque is being applied at this instant the plug will turn. Another form of raking involves using a diamond shaped tool. This tool is inserted all the way into the keyway and jerked out very very fast. This motion tends to throw the pins apart because of inertia. This opens the area at the shear line permitting the plug to turn.

Yet another form of opening a pin tumbler lock, while not picking in the purest sense, is with a tool known as a snap pick. The mechanical principle behind this method is the same as used with more expensive pick guns. A snap pick is shown in Figure 9. It is kind of an overgrown safety pin looking device made from spring steel. The "pick" portion of this tool is inserted into the keyway and held so that it just touches the bottom pins (all of them at the same time). The thumb presses the bail down then releases it. The bail snaps back hitting the pick. This imparts a sharp rap to the bottom pins. The bottom pins, remaining relatively stationary, transfer this force to the top pins which move upward, compressing the spring. This results in the top and bottom pins being apart at the shear line for ever so small a period of time. If at this time a slight turning force is being applied, the plug will turn.

Any who has played pool can appreciate this method. For example: the number one and nine ball are just touching. You strike the nine ball with the cue ball. The nine ball remains stationary while the number one ball moves. This very same principle applies when using a pick gun which we will now discuss.

Pick Guns - Perhaps the most misunderstood tool to the uninitiated is the lock pick gun as we choose to call it. Over the years there have existed several versions of this basic tool. The most popular one is pictured in Figure 10. A Taiwan version is shown in Figure 11. Clever those Chinese.

On the outside of the American made version of this tool is stamped the Patent Number 1997362. We are amused at the thought of the Chinese ordering a copy of this patent from the U. S. Patent Office as we did. It just so happens that Patent Number 1997362 was assigned on April 9, 1935 to E. A. Davis for a two compartment water bucket!!!!!! Seems you just can't trust

anyone anymore.

One advertisement for a pick gun tool cautions the reader that complete identification must be provided for ordering this tool which, in the wrong hands, could virtually cause a "crime wave". This is pure bologna! These tools require as much, if not more skill than conventional picking and most agree that a skilled picker with a hand pick is better equipped than someone with little or no skills armed with a pick gun. The only application where this tool has an advantage is on cylinders equipped with mushroom pins or other similar pin design which makes conventional picking a lot more difficult, sometimes impossible. Mushroom pins are discussed in a later portion of this book.

The picture in Figure 12 shows the pick gun being used. It is a two handed operation with one hand using the conventional torsion wrench to impart a slight turning force. The drawing in Figure 13 better shows how the pick gun works. Internally, the pick gun is akin to a double action revolver. Squeezing the long "trigger" forces an internal "hammer" to compress an adjustable spring. Near full compression, the sear releases the hammer for its forward travel at the end of which it hits the pick holder. This causes the pick to travel upward in a snapping motion. If properly held in the keyway it will impart the same motion to the tumbler pins as did the snap pick. The drawing in Figure 14 better shows just how this happens.



fig. 10

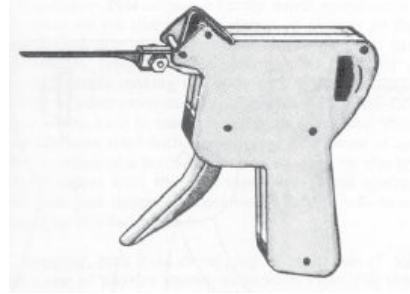

fig. 11

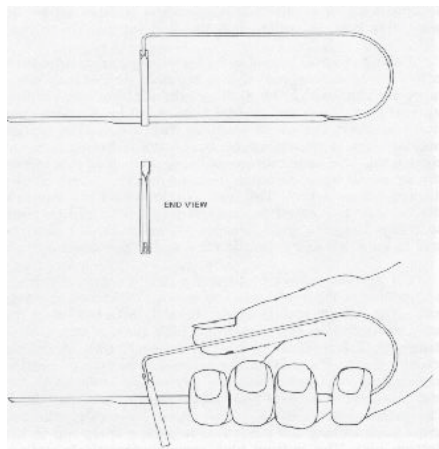

fig. 9

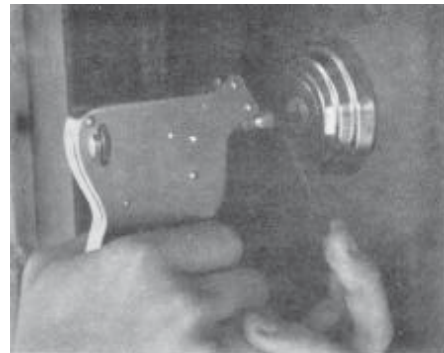

fig. 12



fig 13

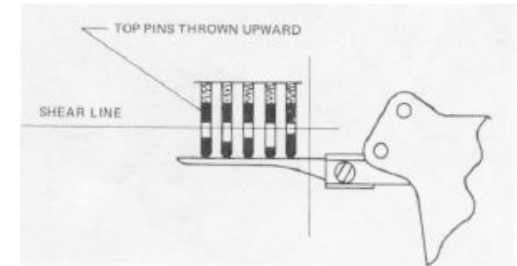

fig 14

Rapping - This subject is hardly worth mentioning, however, since we are discussing, methods of causing all the pins to be thrown into a position whereby the plug can turn, we might touch, briefly, on the technique of "rapping". basically this entails striking the body of the lock with a plastic, rawhide or other protective hammer in the opposite direction than the pins have to travel to reach the shear line. This technique has been used with some degree of success in opening padlocks where the latch dog was acted upon by this transfer of force rather than the pins themselves. Most quality padlocks have had design improvements to preclude to ease of opening by this technique.

Snapping, pick guns or rapping all make use of one well known law of physics known as Newton's law. For the benefit of those who slept through physics class this law briefly states that an object in motion or at rest will remain in that state until acted upon by another force.

Rocker Picks - This method is another rather hybrid method of opening a lock without the key. Some typical rocker picks are shown in Figure 15. These are usually made for a particular brand or type of lock as the random depth cuts must be fairly accurately spaced apart. The back side of the pick is ground to an oval; hence the name rocker pick. A typical set of these will have 10 or more different picks, the only difference being the different random cuts. The whole idea here is that with enough different cut combinations together with an applied rocking motion once the tool is inserted into the keyway, somewhere along the way all the pins will, by chance, be raised to the shear line at the same time.

Picks for Tumbler Locks - The typical tubular lock has 7 pins located radially around a center post. This is considered to be a high security lock and is usually found in laundromat equipment, coin changers and vending machines. The picture in Figure 16 shows a commercially available pick tool for this type of lock. This tool departs from the techniques



fig 16

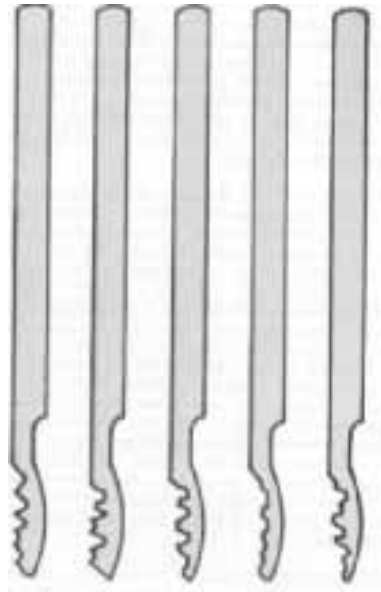

fig 15

and principles we have gone over thus far. This tool imparts a turning torque also, and therefore a separate torque wrench is not required. The tool actually impressions more than it picks. It has 7 thin steel fingers that, when a certain in & out motion is applied to the tool while also applying a slight turning force, adjust themselves to correspond to the cut depth of the key that would open the lock. A rubber band or rubber sleeve provides friction to hold the fingers semi-firmly in place. Once the lock opens the fingers are held tighter by applying another rubber band or tightening a rubber sleeve. When this is done the tool can be used as a key to open the lock or as a guide to cut a permanent key on a special key duplicating machine. The picture in Figure 17 shows this tool in actual use.



fig 17

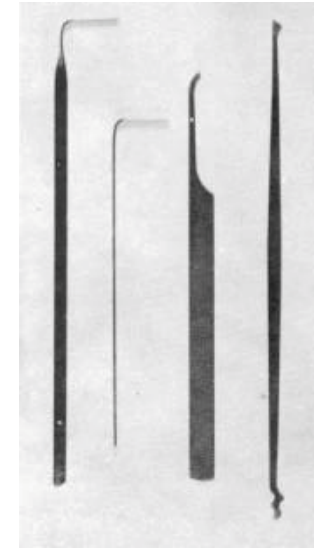

fig 18

COMMERCIALLY AVAILABLE PICKING TOOLS

Picks Sets - Almost as interesting as the evolution of locks is the evolution of lock picking tools (especially in the last few years). Archeological finds indicate lock picking tools have existed almost as long as locks themselves. In latter years professional pick sets for the locksmith trade ranged from two or three basic picks (which most professionals prefer) to a student set of six to ten picks. Now if you really want to impress your peers you can obtain a super deluxe set containing literally dozens of different picks, torsion wrenches, broken key extractors, etc., all contained in a genuine leather, double fold out, zipper closed case!!!

For years this was the way it was pick sets didn't increase in quality or useful design only in the number of picks and fancier cases to hold them. Tool manufacturers finally wised up and in the last few years have introduced smaller, better designed, and more practical sets than before.

When pick design stalemates, the manufacturers seem to concentrate on handle design or a novel way to package or contain the pick set. Pictured in Figure 18 you will see a basic set of two picks and a torsion wrench. This simple set will do about all a set with dozens of picks will do. Pictured in Figure 19 is a super fancy set for the elite picker. Pictured in Figures 20 and 21 you will see examples of better thought out and more practical pick sets. The trend to a different and exotic or novel way to package a pick set is shown in Figures 22 and 23. Here an attempt to present a "jack knife" type of tool set has been done. Actually this approach to pick set packaging is nothing new; the OSS (forerunner of the CIA), during WW II, designed a pick set contained in a real jack knife handle. Whether this was for convenience of concealment we are not quite sure. Some locksmiths have taken a regular pocket knife and ground picks from the blades. This is a questionable approach as the blades are made from hard and fairly brittle steel, they break too easily.

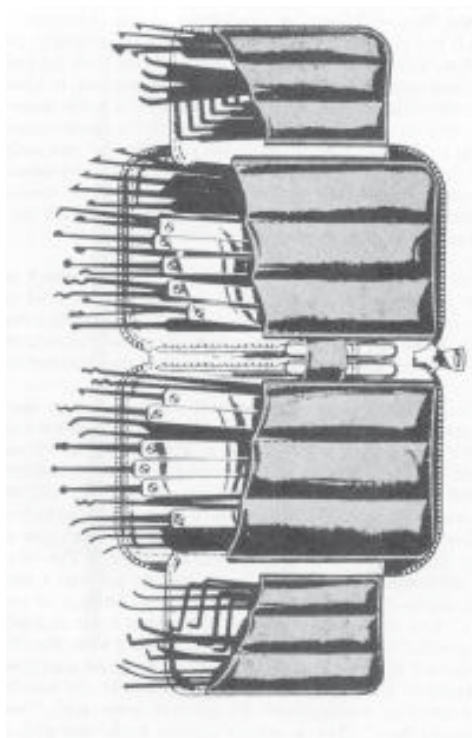

fig 19

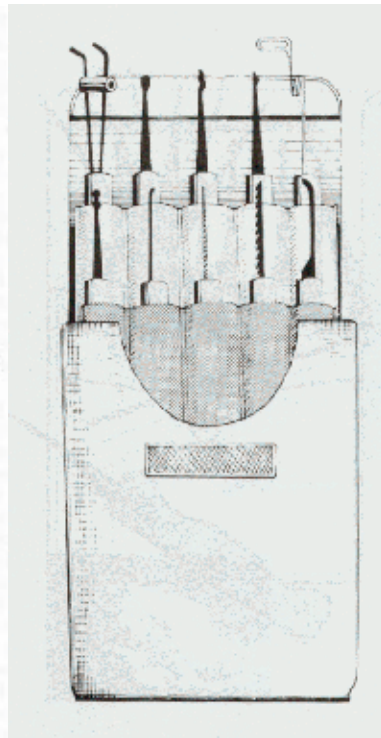

fig 20

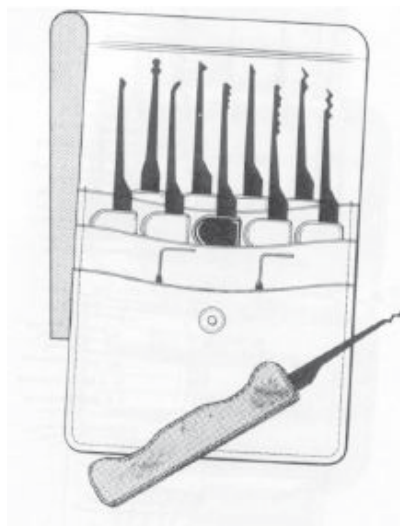

fig 21

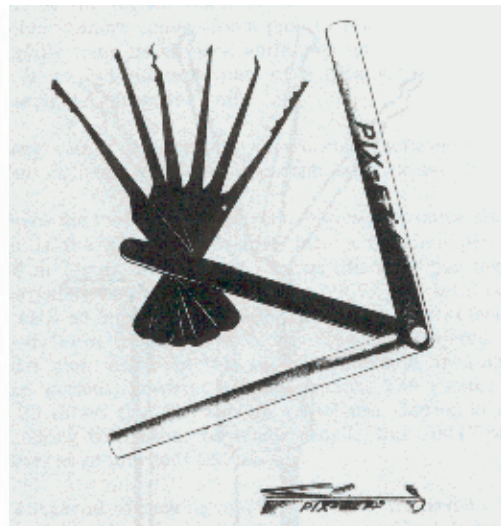

fig 22



fig 22

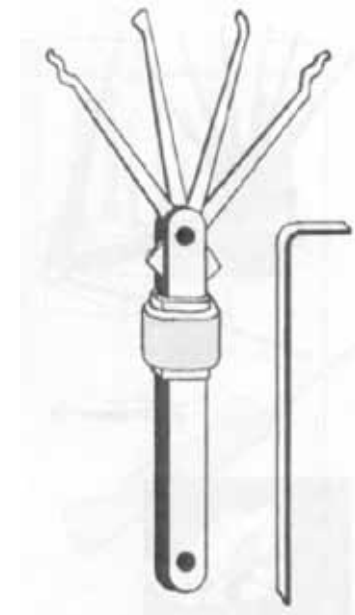

fig 23

Yet another approach to this problem is to break or grind off all the regular blade except for about 1/4 in. then silver solder a more conventional pick to the stub thus making a slightly more usable jack knife pick set. Since a torsion wrench is an indispensable part of a pick set, it must be carried separately from the knife.

In any case it is refreshing to see manufacturers take a fresh (or at least different) approach to pick set design.

Perhaps the most innovative pick set design to come along recently is the pick set designed into a fountain pen as pictured in Figure 24. Figure 25 shows this same pen taken apart, revealing its "innards". Called a "007" pick set it contains 2 each of 3 basic pick styles: diamond, rake, and feeler. The need for a torsion wrench was cleverly answered by using the clip, which in this case is removable making a less than perfect, however, usable wrench. The picture in Figure 26 shows this pen tool in actual use. Carried in the pocket, along with other pens and pencils, this "007" pick set appears as an innocent felt tip pen.

One method of picking and type of lock we haven't yet discussed is the double sided lock. This type of lock is found on storage cabinets, desks and other medium security applications. Several years ago they were found on some vending machines. However, the tubular lock has now all but totally replaced them. Do not confuse the locks and keys used on Ford automobiles with double sided locks. The Ford lock is single sided - only the key is double sided, the purpose being that it can be inserted either way.

The picture in Figure 27 shows a typical double sided lock disassembled. Typically, these locks are of disc tumbler construction. You can see how these spring loaded wafers protrude from the plug. Installed into the housing, these wafers prevent the plug from turning.

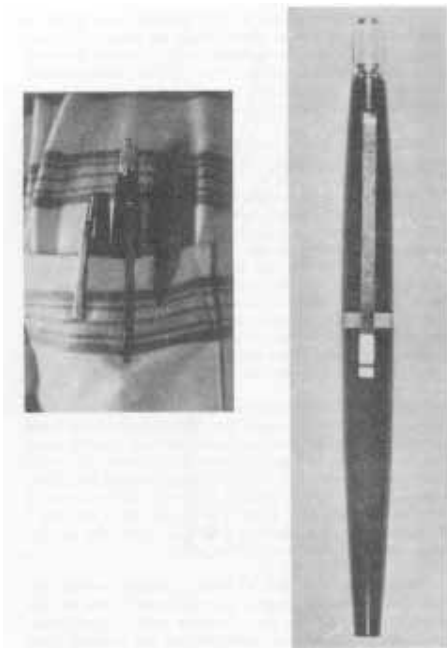

fig 24

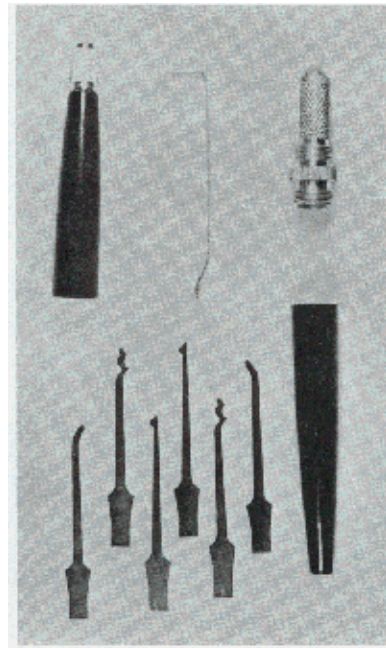
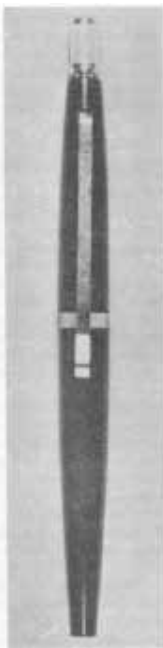

fig 25

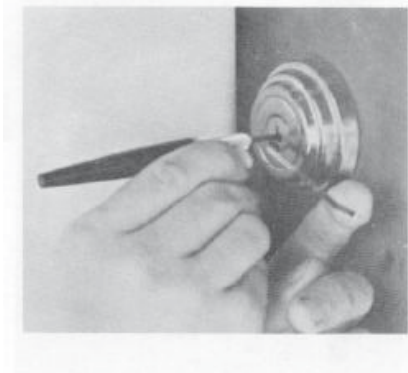
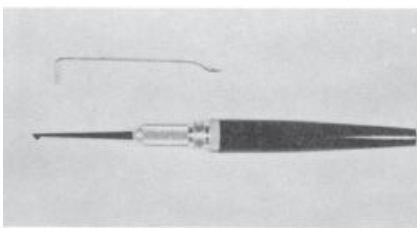

fig 26

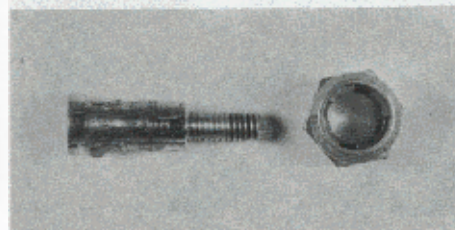
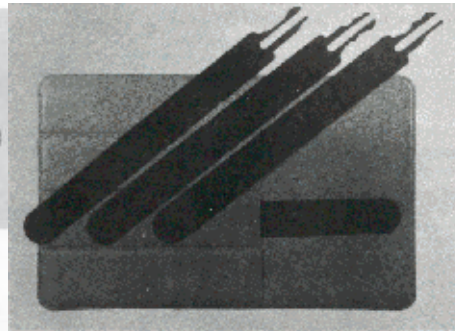

fig 27

The picture in Figure 28 shows a set of commercially available double sided picks. Technically, these are a combination of a rake, a rocker pick and a try out key. The different tumbler cuts together with an up and down rocking motion will usually result in one of these picks opening the lock.

The picture in Figure 30 shows such a pick inserted into the plug previously shown. We can see that the tumblers are pulled back into the plug enough to let it rotate if it were in the housing. The fingers of these picks are slim, of hardened steel, and are easily broken if care is not exercised while applying the up and down motion.

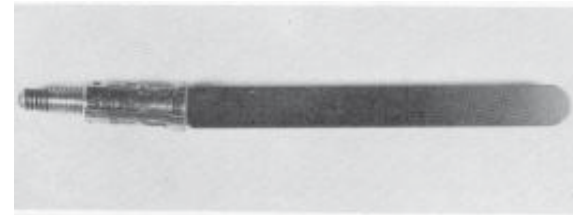

fig. 30

Schlage Wafer Picks - Pictured in Figure 31 is a unique set of picking tools. These are made specifically for picking the Schlage wafer tumbler lock. The set consists of two pairs of modified keys and two picks. These are pictured together with a pair of regular keys for comparison. These two pairs of modified keys are necessary because of Schlage's two different keyways and key tip configuration.

The drawing in Figure 32 shows the configuration in which this tool is used. The modified key provides a picking function, and also provides torque to facilitate the picking.

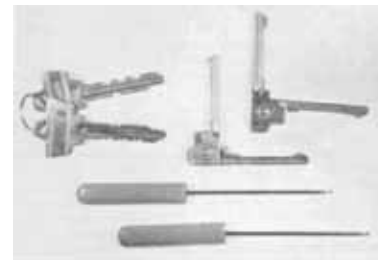

fig. 31

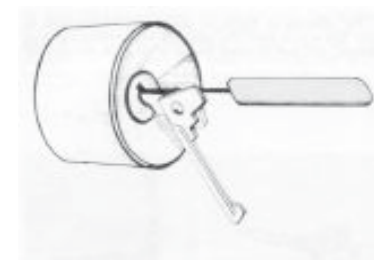

fig. 32

IMPROVED PICKING TOOLS

Today there are literally hundreds of commercially available tools for the locksmith. Most of these tools started out as homemade versions and many of the commercially available tools around today can be, and have been duplicated by those handy with hand and machine. Only a few locksmithing tools require expensive or precision manufacturing machinery and processes. Most picks can be made by bending and grinding pieces of steel wire and flat steel spring material.

Any flat spring material ranging in thickness from .015 to .035 can be fashioned into a pick with the aid of a small grinder. One of the most common sources of such material is an automotive feeler gauge. These gauges have blades ranging in thickness from .001 to approximately .040 of an inch.

The picture in Figure 33 shows an improvised "jack knife" pick set which was made from an automotive feeler gauge. There are enough blades in a set like this to allow hand making a complete set of special and custom picking tools and shims.

One of the most original improvised pick sets to show up is pictured in Figure 34. This "007" type device was built around a readily available hobby knife. A similar knife, before modification is shown in Figure 35. The hollow handle is normally pressed on to the aluminum collet. On the improvised pick set this hollow has been altered to provide a slip fit, allowing it to be readily removed for access to its contents which happen to be a custom pick set together with a small torsion wrench. The clear plastic cap was painted black on the inside. This little jewel turns out to be more incognito than any commercially available set around today.

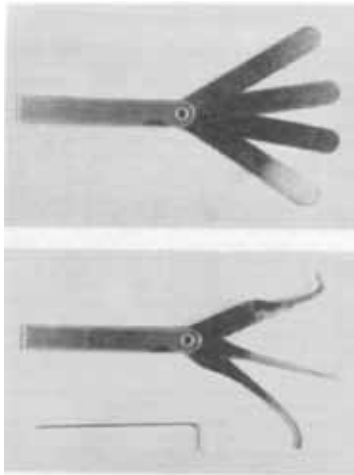

fig 33

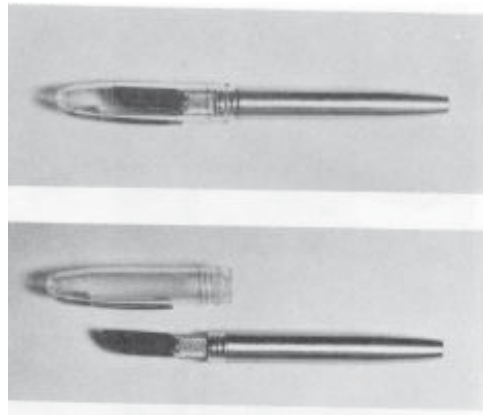

fig 35

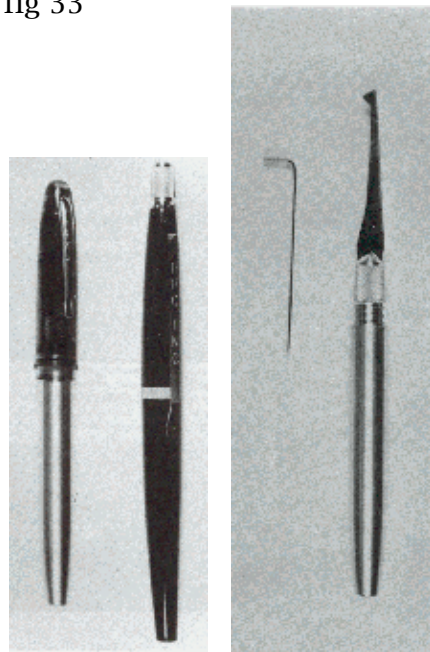

fig 35

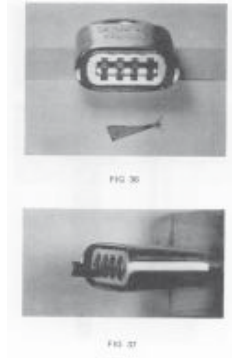

fig. 36. & 37.

Picking the Sesame Padlock - This popular type padlock is shown in the picture in Figure 36. It has four combination wheels each being numbered from 0 to 9. The most unique feature of this padlock is that the combination numbers can be changed easily. This is accomplished while the lock is open by inserting a special tool into the open shackle hole and resetting the wheels to any desired new number.

Internally, these wheels have a changeable hub which has a flat spot on it. When these four flat spots are aligned together toward the side of the lock having the trademark stamped on it, the remaining mechanism can move so as to unlock the shackle.

Also pictured in Figure 36 is an improvised picking tool for this lock. Actually this tool does not pick the lock but aids us in determining an unknown combination number. The picture in Figure 37 shows this tool inserted into the lock. Being made from .005 shim stock, it slips between the wheel and housing. In the position shown it is used to feel for the flat spot as the wheel is turned. Once the flat spots are found, 5 is either added or subtracted from the indicated number to have the correct combination number.

HANDCUFFS

A book on lock picking for police would not be complete without a brief look at handcuffs. This is one locking device that is close to daily activities of almost every law enforcement officer. Every officer should be familiar with the locking mechanism, especially how easily handcuffs can be picked open.

With the exception of a few low cost imports, there are two popular brands of handcuffs used in the United States. These are the Peerless and the Smith & Wesson. These are almost identical in design and construction. Both have a double lock feature for the benefit of both the cuff and the cuffee. On double locks, the jaw cannot be closed any tighter, thus cutting off the circulation and also cannot be shimmed open with a bobby pin.

The picture in Figure 38 shows a pair of Smith & Wesson Model 90 handcuffs together with keys. The keyways can be seen. The keys are small hollow bit keys with a pin-like protrusion extending from the bow (handle).

The picture in Figure 39 shows the double lock plunger hole that is on the side of the frame on both cuffs. The double lock feature is activated by pressing the pin on the key into this hole. The double lock is unlocked by inserting the key into the keyway and turning the opposite direction than when just unlocking the jaw.

Because of their small profile and light weight design, handcuffs have the simplest of lock mechanisms. While these locks are strong and are generally secure enough for their application, a law enforcement officer should be aware just how easy they are to open. The picture in Figure 40 shows these cuffs being shimmed open with a thin piece of steel. Over the years, bobby pins have become just about the standard tool for this operation, probably because of their presence almost everywhere including the crack in the rear seat of your patrol car. When was the last time you checked this before taking a car out?

The pictures in Figures 41 and 42 show a ball point pen's insides and the cuffs being opened by a key fashioned from this pen. In this particular case, the inside of the ball point pen was transformed into a handcuff key in about five seconds with the only tool being a nail clipper. With a little more time and effort a much better improvised key could be made.

We hope that these two simple illustrations have made the point of how important it is to keep even the simplest of raw materials away from the dexterous cuffee.



fig 38



fig 39

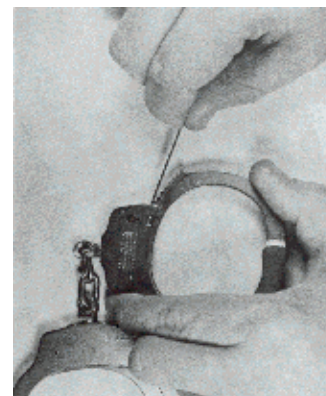

fig 40

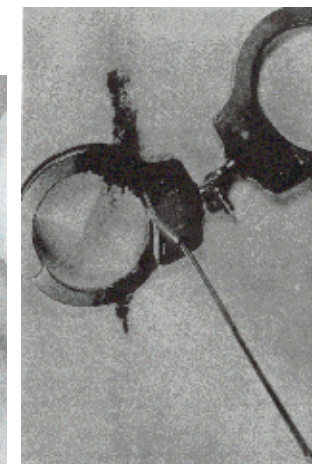

fig 42

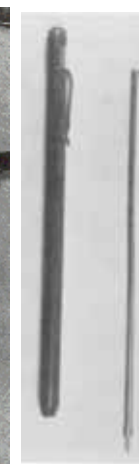

fig 41

CONCLUSION

You, the reader, have just seen most of the inner secrets of lock picking. We have looked briefly at some of the more common types of locks and the established ways of picking each one.

While the tools used differ, the basic ingredients of skill and dexterity remain the same. Lock picking is not easy. You may "luck out" sometimes but will usually spend several minutes, sometimes hours before succeeding. No lock picking tool will perform by itself any more than an artists paint brush.

Lockpicking is hardly a skill of the fence hopping, run of the mill burglar. He seldom has the knowledge or patience. These operators usually find enough open windows and unlocked doors to satisfy their needs.

Lock picking enters the larcenous arena when the stakes are high. These stakes are usually items of high monetary value when burglary is concerned or intelligence gathering where espionage is involved. It is only here where the high security and "pick resistant" locks are really worth their extra cost and only then when combined into an overall physical security system. For the average home owner the extra security afforded by pick resistant locks should be added only after tending to more vulnerable points of security on their premises.

With little or no expenditure, existing locks can be made more secure by ascertaining that there is enough difference in the cuts on the key so as not to allow a knife blade or similar straight instrument to lift the tumblers to the shear line. It is also good practice to eliminate master keying found in most tract homes. Recently purchased or rented homes should be rekeyed by the new occupant. You can never be sure just who the former owner or occupant gave keys to.

In "pick resistant" lock design, attention is usually focused on the pins. The "mushroom" pin was one of the first attempts to foil regular picking techniques. Here the top pin, rather than being a straight, smooth sided pin is machined to appear as a small, mushroom shaped spool. If you are now familiar with basic pin tumbler design, you can readily see how these work.

All in all there needs to be more attention to complete home security rather than concentrate on a "pick proof" lock or cylinder. The extra cost of this lock might be better spent in other areas of physical security. This does not mean such a lock won't enhance an already good system, only that it should be considered in the proper perspective.

Contents

Introduction	1
Tools	2
Lock Identification	5
Pin Tumbler Locks	5
Wafer Tumbler Locks	7
Double Wafer Locks	9
Pin and Wafer Tumbler Padlocks	10
Tubular Cylinder Locks	10
Mushroom and Spool Pin Tumbler Locks	12
Magnetic Locks	13
Disk Tumbler Locks	14
Opening a Combination Padlock	16
Tips for Success	18
Some Precautions	20
Nobody's perfect	21
Learning to Touch and Feel	22
Visualization	22
Illustrations	24

INTRODUCTION

The ancient Egyptians were the first to come up with a complicated security device. This was the pin tumbler lock. We use the same security principle today on millions of applications.

The most commonly used lock today is the pin tumbler lock. A series of pins that are divided at certain points must be raised to these dividing points in relationship to the separation between the cylinder wall and the shell of the lock by a key cut for that particular series of pin divisions. Thus the cylinder can be turned, and the mechanism or lock is unlocked.

Lock picking means to open a lock by use of a flat piece of steel called a pick. Actually, the process requires two pieces of flat steel to open cylinder locks. It amuses me to watch spies and thieves on TV picking locks using only one tool. But it is for the better in a sense. If everyone learned how to pick locks by watching TV, we would all be at the mercy of anyone who wanted to steal from us, and the cylinder lock for the most part would be outdated.

The actual definition of lock picking should be: “The manipulation and opening of any restrictive mechanical or electronic device by usage of tools other than the implied instrument (key or code) used solely for that device.” A little lengthy, but more accurate description. With cylinder locks, it requires a pick and a tension wrench.

By picking the lock, you simply replace the function of a key with a pick that raises the pins to their “breaking point,” and using a tension wrench one rotates the cylinder to operate the cam at the rear of the lock’s cylinder to unlock the mechanism. (See Fig.1-2 .page 24)

The tension wrench is used to apply tension to the cylinder of the lock to cause a slight binding action on the pins as well as to turn the cylinder after the pins have been aligned by the pick; this opens the lock. The slight binding action on the pins caused by the tension wrench allows one to hear and feel each pin as it “breaks” or reaches alignment with the separation of cylinder and shell. The vibration is felt in the knuckles and joints of the fingers, and the sound is similar to that of a cricket in an arm wrestling match a subtle yet distinct click.

Usually you need very little tension with the wrench while picking the lock. In fact, it takes somewhat of a delicate, yet firm touch. This is the secret to picking locks successfully—a firm and yet gentle touch on the tension wrench. You should be able to feel the pins click into place with the right amount of tension; experience will be your true guide.

Half of your success will be based on your ability to use or improvise various objects to use as tools for your purpose. The other half will depend on practice. I once picked a pin tumbler lock using a borrowed roach clip and a hairpin. A dangerous fire was prevented and probably several lives were saved. The world is full of useful objects for the purpose, so never hesitate to experiment.

TOOLS

I started picking locks using a small screwdriver and a safety pin. The screwdriver can be used as a tension wrench, and the safety pin is used like a “hook” pick. The last half inch of the screwdriver’s tip was bent at a 45 degree angle so as to allow easy entry for the pick (bent safety pin). Do not heat the screwdriver tip to bend it, as this will destroy its temper. Use a vise and hammer to do the job. Bend slowly by using firm and short taps of the hammer, otherwise you may break and weaken the shaft. The safety pin should be about one and a half inches long and bent in the same way.

With the small screwdriver as a tension wrench, you can use more of a turning or twisting movement than with a regular tension wrench so you will generally need less direct force when using it. As I mentioned earlier, with practice you will develop the feeling for the right amount of tension on a cylinder. If the safety pin bends after a short time, use the keyway of the lock you are picking to bend it back into shape. Even after several times of bending, it should still be useful. Keep a few spares handy, though. File the tip of the safety pin flat in relationship to the bottom of the pins in the lock. Smooth any sharp edges so that you won’t impale yourself. Also, if the tip is smooth, the pick will not get hung up on the pins while picking the lock. Granted these are not the best tools for the job, but they do work. If you learn to use your junk box as a rich source of equipment, then with your experience real lock picks will give you magic fingers. Also, you’ll have the advantage of being able to improvise should you be without the real things (which are illegal to carry on your person in most parts of the country).

Lock picks are difficult to get. I received my first set when I became a locksmith apprentice. All of my subsequent sets I made from stainless steel steak knives with a grinder and cut-off wheel. They are much more durable than the commercial picks. If you do make your own, make certain that the steel is quenched after every 3 seconds of grinding—do not allow the pick to get hot to the point of blue discoloration.

A diamond pick is the standard pick I use on most all pin and wafer locks. A small diamond pick is used for small pin tumbler locks such as small Master padlocks, cabinet file locks, etc. The tubular cylinder lock pick, we will discuss later. The double-ended, single-pronged tension wrench is used with the diamond pick. It features double usage; a small end for small cylinders and a large end for the larger cylinders. A special tension wrench is used for double-wafer cylinder locks with an end with two prongs on one end and tubular cylinder locks with the single prong on the other end. We will discuss tubular cylinder and double-wafer locks later as well. The steel should be .030 inches to .035 inches thick for the picks and .045 inches to .050 inches thick for the first tension wrench mentioned above. The second tension wrench should be .062 inches square (.062 inches x .062 inches) on the tubular cylinder side (one pronged end), and .045 inches thick on the double-wafer end (two-pronged end). You can accomplish this by starting out with .045 inches in thickness.

The two-pronged end should be bent carefully in a vise at a 30 degree angle. This allows easy entry for the pick on double wafer locks. (See fig. 3. page 25)

Among the more common tools used by professionals around the world is the rake pick. The rake pick is used to “rake” the tumblers into place by sliding it in and out across the tumblers. I seldom use the rake pick because it is not highly effective and I consider it a sloppy excuse for a lock pick. I’ve seen the rake pick work on some difficult locks, but you can rake with a diamond pick and get the same results. I prefer the diamond pick for most tumbler locks simply because it is easier to get in and out of locks—it slides across the tumblers with little or no trouble.

A ball pick is used for picking double-wafer cylinder locks, though I never carry one; I use a large diamond pick and reverse it when picking these locks. This means I have one less pick to carry and lose. (See Fig. 4-5. page 26)

A double-ball pick is used like a rake on double-wafer locks in conjunction with a tension wrench (two-pronged end).

A hook pick is used to open lever tumbler locks, though again, I use a diamond pick with a hooking action when possible. There are various sizes of hooks but they all have the same basic job-to catch the movable levers that unlock lever locks.

There are also various sizes of tension wrenches. They are usually made from spring steel. The standard tension wrench is used for pin and wafer locks. A special tension wrench is called a Feather Touch, and it is used for highsecurity mushroom and spool pin tumbler locks.

Its delicate spring-loaded action allows the pick to bypass the tendencies of these pins to stick. A homemade version of the Feather Touch can be made from a medium-light duty steel spring.

As to getting lock picks for your own use, you cannot go down to your local hardware store and buy them. I could supply you with some sources or wholesalers, but I do believe it is illegal for them to sell to individuals. Your best bet would be to find a machine shop that will fabricate them for you. It would be less expensive and arouse less suspicion if you purchase a small grinder with a cut-off wheel and make your own. With a little practice, you can make a whole set in an afternoon. Use a copy of the illustrations in this book as templates and carefully cut them out with an X-ACTO knife. Cut down the middle of the lines. Acquire some stainless steel (many steak knives approach proper thickness).

With a glue stick, lightly coat one side of the paper template and apply it to the cleaned stainless surface, and allow it to dry. You'll need a can of black wrinkle finish spray paint. This kind of paint has a high carbon content and can stand high temperature of grinding. Spray the stainless (or knives) with the patterns glued on and dry in a warm oven or direct sunlight for one hour. Set aside for twenty-four more hours. Peel off the paper template and you are ready to cut and grind. Please use caution when cutting and grinding. The piece should be quenched every three seconds in cold water. Smooth up sharp edges with a small file or burnishing wheel. Tools made from stainless steel will outlast the purchased ones. The tools purchased from most suppliers are made from spring steel and wear out after about 100 uses. The stainless steel ones, if properly made, should last over 2,000 uses.

LOCK IDENTIFICATION

There are many types of locks, the most common being:

1. The pin tumbler lock. Used for house and garage doors, padlocks, mail boxes, and Ford automobiles.
2. The wafer tumbler lock. Used for garage and trailer doors, desks, padlocks, cabinets, most autos, window locks, and older vending machines.
3. The double-wafer lock. Used for higher security wafer tumbler applications.
4. The warded locks. Used for light security padlocks and old-fashioned door locks.
5. Lever locks Used for light security and older padlocks, sophisticated safe-deposit boxes, some desks, jewelry boxes, and small cash boxes.
6. Tubular cylinder locks. Used for alarm control systems, newer vending machines, car-wash control boxes and wherever higher security problems might exist.

These locks are the more common locks used yet there are variations and combinations of these principal types that usually pick open in the manner that will be discussed. Some of them just require practice of the basic types, others luck, and most of the rest of them knowledge of how that particular lock works and is keyed. This comes from experience.

(See fig. 6-7. page 27)

PIN TUMBLER LOCKS

Pin tumbler locks offer the most security for their price. They have close machine tolerances and approximately 1,000,000 different key combinations for a five-pin lock. Considering the thousands of different companies making pin tumblers (different shaped keyways for each company or design line), the chances of someone having a key that will work in your front door lock are one in many billions.

Pin tumbler locks can easily be identified by peering down the keyway and locating the first round pin. Sometimes you can see the pin's dividing point, where it breaks with the cylinder wall (shear point).

To successfully pick a pin tumbler lock, your sense of touch should be honed so that both hands feel the tools. Once the hand holding the pick has located a slight relief in tension while picking a particular tumbler, the other hand holding the tension wrench will feel a relief or breaking point. Both hands should be involved with the sense of touch, the sensing of the inner workings of the lock.

We are now ready to begin the first lesson. First open your front door and check for a pin tumbler lock on it. It should have one on it. If there is one, leave the door open to decrease suspicion. Do not lock yourself out of your apartment or house by being overconfident; not only will you raise suspicion, but window glass is not cheap.

HOW TO PICK A TUMBLER LOCK

STEP ONE

Without using the tension wrench, slip the pick into the lock. The “hook” of the pick should be toward the tumblers (up in most cases, depending on whether or not the lock was mounted upside down-you can tell by looking down the keyway and locating the first pin with your pick). Try to feel the last tumbler of the lock. It should be 7/8 inches into the lock for a five-pin tumbler lock (most common pin tumbler lock used).

Make certain that you have no tension on the wrench when inserting the pick as this will encumber the frontal tumblers. When you feel the back tumbler, slowly raise it with a slight prying motion of the pick. Release it, but keep the pick in the lock on the rear tumbler.

Now insert the tension wrench, allowing room for the pick to manipulate all of the pins. It should be placed at the bottom of the cylinder if the lock was mounted upright, tumblers toward the top of the cylinder. Apply firm and yet gentle clockwise pressure to the tension wrench.

Slowly raise the back tumbler with a slight prying motion of the pick. A minute click will be felt and heard when it breaks. It will lose its springiness when this occurs, so do not go any further with it. Any further movement with the pick will cause binding by going past the pins’ shear line. Continue an even pressure with the tension wrench.

Keeping an even tension pressure, proceed to Step Two.

STEP TWO

The fourth tumbler should be easily felt since it is the next one in line. Raise it until it breaks, keeping the tension wrench steady. It too will give a sound and sensation when it breaks or aligns.

STEP THREE

The third or middle tumbler is next. Again, it too will click. Maintain a constant, even pressure on the wrench - about the same pressure that you would use to replace a cap on a ketchup bottle. You may feel the “clicks” in your tension wrench as well as hear them.

(See Fig.8-11. page 28)

STEPS FOUR AND FIVE

Continue on to the next tumbler out, working toward you. When it breaks, raise the last (front) tumbler to its braking point and the cylinder should be free to rotate and unlock the door. Sometimes you may have to play with the wrench to open the lock because you may have raised a tumbler too high, past its breaking point. If this is the case, very slowly and gradually release the tension wrench pressure and the overly extended tumbler will drop into its breaking point before the other tumblers have a chance to fall. The cylinder should pop open at that point. I have found that this technique is responsible for over 30 percent of my successes in opening all tumbler locks.

If the lock still refuses to open after all that treatment, release the tension wrench pressure, allowing all of the tumblers to drop and start over. You may have more than one tumbler too high and would be better off to repeat the picking process.

WAFER TUMBLER LOCKS

Wafer tumbler locks make up over one-fourth of the locks in use in the world. Since they are generally easier to pick than most pin tumbler locks, you will be 75 percent master after fooling around with these mechanisms. That is why I wrote about pin tumbler locks first-they are more difficult and make up over one-half of the locks used today.

(See Fig.12-14. page 29)

The term wafer refers to the general shape of the tumblers. The wafers are flat, spring-loaded tumblers that are much thinner than pins and the distance between them is less. Wafer locks are picked in the same way as pin tumbler locks, but you must compensate for the smaller dimensions. You can identify wafer locks simply by looking down the keyway and locating the first flat tumbler. The last tumbler on most wafer locks is located about one half inch into the lock.

Wafer locks are used on filing cabinets, lockers, most cars, garage doors, desks, and wherever medium security is required. The only wafer tumbler lock in common use that is difficult to pick is the side-bar wafer lock. It is the most popular type of auto lock. This lock is of different design than most other locks and offers much more security than a regular wafer tumbler lock, or even a pin tumbler lock.

The side bar lock is used mostly on General Motors cars and trucks since 1935. It is used on ignitions, door, and trunk locks. Side bar locks are hard to pick because you cannot feel or hear the tumblers align with the cylinders breaking point. A spring-loaded bar falls into place to allow the cylinder to turn when all of the tumblers are aligned. There is no way to tell when that happens. One learns to sense the bar while picking so that it seems to fall into place by itself. But for beginners, I recommend this technique for emergency openings: Peer down the keyway and locate the side groove of any of the tumblers using a pick as a searching tool. Drill a small hole in the shell of the lock above the bar which is above the groove on the tumblers. Since side bar locks have off-centered keyways, the usual place to drill is opposite of the keyway. Using an L-shaped steel wire, put pressure on the sidebar and rake the tumblers using a tension wrench for cylinder rotation and the lock will open.

Fortunately, most GMC autos have inferior window seals; with a coat hanger, one can lasso the locking door knob to open the door. If you are going to be successful at opening side bars, you will do it within two minutes; otherwise, you are causing unnecessary wear on your picks not to mention wasting your time.

Ford auto locks are relatively simple to pick. They have pin tumblers and you have to remember that the door locks turn counter clockwise. Most other auto locks turn clockwise. If you are not sure, remember this: If the tumblers will not catch at their breaking points, you are going in the wrong direction with the tension wrench.

Wafer locks are a cinch to pick if you have learned how to pick pin tumblers. Just remember that wafers are thinner than pins and there is less distance between them.

Generally you need less tension-wrench pressure with these locks, yet car locks can be quite stubborn and require a great deal of tension. Any heavily spring-loaded cylinder needs a substantial amount of tension.

As a rule, though, wafer locks need less play with the tension wrench than with pin tumbler locks. But if you find yourself having difficulty in opening these, you may try a little tension-wrench play. Usually they won't pop open like pin tumbler locks, they just slide open; you don't get the warning that a pin tumbler gives before it opens because there is less contact area on the wafer's edge than on a pin, so the sense of climax is reduced with these types of locks. Still, they open quite easily.

DOUBLE WAFER LOCKS

Double-wafer locks are picked in the same way as single wafer locks, but there are two sides to the story. Not only do you have to align the top wafers, but you have ones in the bottom of the cylinder to align as well.

The Chicago Lock Company was the first to come up with this type of lock. It is a classic example of the race toward better security. Certain tension wrenches allow uninterrupted picking using ball picks. You can also use a standard tension wrench or small screwdriver and place it at the center of the keyway. To eliminate unnecessary baggage, use a diamond pick, reversing it to encounter both top and bottom wafers. (See Fig.15-16. page 29)

The last tumbler in this type of lock is located less than one-half of an inch in. The picking procedure may have to be repeated more than one time; top wafers, then bottom wafers, top, bottom-back and forth. Yet these locks are easier to pick than most pin tumblers.

Locate the last wafer on the top side and move it to its breaking point. Do the same with the other top wafers. Keep the tension wrench firm, remove the pick, turn it upside down (if you are using a diamond or home-made pick), and reinsert it to work the bottom wafers. You may have to repeat this process a few times, but double-wafer locks can and will open

with such treatment. Schlage has a doorknob lock that opens this way, but the last tumbler is about one and one-half inches in.

Double-wafer locks are easy to master if you have learned to pick pin and wafer tumbler locks. Since doublewafer locks are more compact, you have to compensate for the fact-slightly closer tolerances. These type of locks are used on old pop and candy machines, gas caps, cabinets, etc.

PIN AND WAFER TUMBLER PADLOCKS

Cylinder padlocks require a technique of holding them with the same hand with which you are using the tension wrench. This technique allows one to pick the padlock without going into contortions over a dangling padlock. Assuming that you are right-handed, hold the padlock in your left hand by gripping the body of the padlock with your thumb and forefinger. Insert the tension wrench at the bottom of the keyway and hold it in a clockwise turn with your ring and little finger, causing a slight binding pressure on the cylinder. Now your right hand is free to pick, and your left hand does the job of holding both the lock and tension wrench. The overhand method works well, too, but the thumb controls the tension wrench instead. Switch around to find which is most comfortable for you. When tumbler padlocks pop open, it is quite a sensation because the shackle is spring-loaded and gives one quite a jolt. It's a feeling of accomplishment. You may need a little more tension on padlocks than on door locks because the cylinder cam has to operate a spring-loaded bolt. Overall, padlocks are the most fun to open. Practice using old or discarded padlocks that you have found. I've worn out hundreds of them.

TUBULAR CYLINDER LOCKS

(Note: Diagrams of tubular lock were omitted due to the fact that picking them with conventional methods is a complete waste of time. There are picks available that are specifically designed to pick this kind of lock in a matter of seconds)

We will gradually proceed to more sophisticated locks from here. I would like to remind you that success is not based on personality. If one is arrogant about one's lockpicking skills, one could easily be made a fool of by a lock. And no matter how many times you bash a cylinder, you will still be locked out. The only thing you accomplish is attracting an audience-so be cool. If at this point you have had much difficulty under standing

the principles of pin and wafer locks, please restudy this book from the beginning. Read it several times so as to absorb it. The information that you now have has taken me almost two decades to gather, so please be mindful of that.

Now you are about to learn how to open the more difficult locking mechanisms- some of the other 25 percent of the locks used today. You should feel confident with pin, wafer and double-wafer tumbler locks before you attempt rim cylinder locks.

Tubular cylinder locks stand out as the most generally accepted lock in all important industries using high-quality locks for protection of property, merchandise, and cash. They are recognized as giving the maximum amount of security for their price range.

Tubular cylinder locks are pin tumbler locks arranged on a circular plane. Unlike conventional pin tumbler locks, all of the pins are exposed to the eye. The central section of the lock rotates to operate the cam when all of the seven pins have reached their breaking points. When the proper key is entered into the lock, the tumblers are pressed into position so that the central section (plug) can be turned. This manual operation of inserting the key places the tumblers in position so that the lock can be operated and ensures that frost, dust, salt, or unfavorable climatic conditions will not affect the smooth operation of the lock.

The Chicago Ace lock is a product of the Chicago Lock Company of Chicago, Illinois. It is an effective security device and is used on vending machines, coin boxes, and burglar alarms. A larger, more complex version of it is used on bank doors and electronic teller machines. The key is of tubular shape with the cuts arranged in a circle around the key. The pick used for this lock is the tubular cylinder pick, or you may use a straight pin or your homemade safety pin pick. The one-pronged end of the tension wrench is a little more specialized and is used for rim cylinder locks. It must be .062 inches square for best results. Any square steel stock is acceptable, as long as it fits snugly into the groove of the tubular cylinder plug.

This type of lock is a burglar's nightmare because it takes so long to pick. You have to pick it three or four times to accomplish the unlocking radius of 120 to 180 degrees. And the cylinder locks after each time you pick it every one-seventh of a turn.

If you leave the lock only partly picked, the key will not be able to open it, so you must pick it back into the locked position after opening it—another three or four picking sessions. In all, to unlock and lock the cylinder, you have to pick it up to eight times—quite a chore if you don't have the right tools or time.

These locks almost always pick in the clockwise direction. Make certain that the tension wrench fits snugly into the groove on the cylinder. Very slowly push the first pin down until it clicks, maintaining a definite clockwise pressure on the tension wrench. Once the tumbler has broken, do not push any further and proceed to the next one, and so on. As you reach the last tumbler, the tension wrench will feel more slack and give way if the lock were properly picked.

There are special keyhole saws for these locks in which you drill out the tumblers and turn the cylinder. Also there is a special tool used by locksmiths to open rim cylinder locks.

MUSHROOM AND SPOOL PIN TUMBLER LOCKS

High-security pin tumbler locks may contain specially made pins to make picking them more challenging. The pins are machined so as to make picking them quite difficult. When picking these locks, the pins give the impression that they have broken, when in fact they could be a long way from breaking. You can tell whether or not you are picking a pin tumbler lock that has these pins by the fact that the pins seem to align so easily with a louder than normal click. The cylinder seems eager to open but to no avail. The picking procedure relies on a well-yielding tension wrench. The tension wrench has to be lightly spring-loaded so that the pins can bypass their false breaking points. You also have to “rake” (seesaw in and out) the pins with your pick. The feather-touch tension wrench is ideal for the job. Use light pressure with it, and it will let you in.

(Note: A feather-touch tension wrench is not necessarily required. A normal tension wrench will work fine with an extremely light tension on it. The weight of just your index finger alone should be enough in most cases).

The mushroom and spool pins are used in locks for high-security purposes such as bank doors. The American Lock Company uses them in some of their padlocks.

MAGNETIC LOCKS

Magnetic locks are fascinating. I almost hate to open them because I feel that I have breached their uniqueness. In reality, you do not pick them, but “confuse” them. They generally work on the principle that like magnetic polarities repel each other. The key is a set of small magnets arranged in a certain order to repel other magnets in the lock, thereby allowing the spring-loaded bolt or cam to open the lock.

By using a pulsating electromagnetic field, you can cause the magnets in the lock to vibrate violently at thirty vibrations per second, thereby allowing it to be opened by intermittent tugging of the bolt or turning of the door knob.

This method may also ruin the small magnets in the lock by changing their magnetic status or properties. So, if you have to perform an emergency break-in with these locks, do not relock the door. The card or key will not operate the lock.

The magnetic pick can be used on padlocks by stroking it across the place where the key is placed. It is also designed to fit into the doorknob and is used by stroking one pole in and out or by using the other pole the same way.

If you have had little or no training and experience building something like this, please have a friend who is familiar with basic electronics do it for you. Do not take the chance of electrocuting yourself. Make sure that the coil is also completely covered with electrician's tape after you have wound the 34 gauge wire. Also make sure that the steel core has at least three layers of tape over it. Do not leave the unit plugged in for more than two to three minutes at any one time as this may cause overheating which could cause it to burn out or start a fire. It is safe to use if constructed properly and not left plugged in unattended. Opening magnetic locks requires only 30 to 60 seconds anyway, so don't leave the unit plugged in for longer. For magnetic padlocks, use a back-and-forth stroking action along the length of the keyway. For magnetic door locks, use a stroking in-and-out action in the slot of the knob alternating from one side (pole) of the pick to the other.

The “key” for a magnetic door lock is a metal or plastic card containing an array of magnetic domains or regions coded in a specific order to allow entry. The magnetic pick bypasses that.

(See Fig. 17-19, page 31)

DISK TUMBLER LOCKS

Combination or “puzzle” locks were invented to further improve security and the protection of valuables. The older safes and lockboxes were good security devices when they came into the market, but some people became curious and realized that these safe locks had inherent weaknesses. One of the main problems was that the disk tumblers were not mechanically isolated from the bolt that unlocks the safe door. In other words, you could feel and hear the tumblers while turning the dial by applying pressure on the handle of the bolt.

When that problem was recognized and solved, thieves started drilling through strategic places in the lock itself to open it. Knocking off hinges was an all-time favorite tactic as well. Then came punching out the dial shaft, blowtorching, and just plain blowing the door with explosives. Greed can breed great creativity.

The first problem, that of manipulating the tumblers open, was rectified by making use of the dial to operate the bolt upon completion of the dialing of the correct combination. This made it nearly impossible to feel or hear the tumblers. Drilling was deterred by laminating the safe door with hard steel and beryllium-copper plates. The beryllium-copper plates pull heat away from the drill tip quickly, and the bit just spins without effect; drilling cannot take place without the generation of heat at the bit’s cutting edges. Knocking off hinges was discouraged by using three or more bolts operated by a main linkage network. Punching out the dial shaft to let the tumblers fall out of the way of the bolt was corrected by beveling the shaft into the wall of the safe door.

Presently, safe locks are quite sophisticated. Picking them would require supernatural power. The older safes, however, are much easier and even fun to pick. Picking combination padlocks is a good way to start learning how to open safes, and we will get to them shortly. But first, let us discuss some basic principles of disk tumbler locks.

Disk tumbler locks work by the use of flat, round disks of metal or plastic with a notch and a peg on each disk. The notch is called the tumbler gate. The gate of each tumbler has to be lined up with the pawl of the bolt mechanism by usage of the linking capabilities of the pegs.

The first tumbler of the disk tumbler lock (also the last combination number dialed) is mechanically connected to the dial through the safe door. When the dial is turned, the first tumbler picks up the middle tumbler when their pegs connect. The middle tumbler in turn picks up the last tumbler for one more complete turn and the tumblers have been “cleared”—you are ready to dial the first combination number by aligning the last tumbler’s gate to the pawl. After you have reached this number or position, rotate the dial in the opposite direction one complete turn (for three tumbler locks; two turns for four tumbler locks) to engage the middle tumbler and drive it to the second combination number. By rotating the dial back into the opposite direction to the last combination number, the bolt can be operated to open the lock, or as in the case of newer safes, the dial will operate the bolt by turning it once again in the opposite direction.

One of the innovations that developed to deter sensual manipulation of combination locks was the use of serrated front tumblers (last combination number dialed). These were designed to foil listening and feeling of the tumblers’ gates by burglars.

When the bolt encountered any one of these shallow gates, the safecracker could never be sure whether or not a tumbler was actually aligned with the pawl-bolt mechanism. Some burglars solved this problem by attaching high-speed drills to the dial knob to rotate and wear down the first tumbler’s shallow false gates against the bolt, thereby eliminating them altogether, or at least minimizing their effects. Still, today the serrated tumbler is used as an effective deterrent to manipulation in combination padlocks where space is a factor.

Let us move on to combination padlocks. The most common and difficult to open of these small disk tumbler locks are the Master combination padlocks, and they are quite popular. I have had good luck in opening these locks with a wooden mallet or soft-faced hammer. The manipulation of Master combination padlocks is quite easy—I have done it thousands of times, and you can learn it, too. The newer the lock is, though,

the more difficult it will be to open at first. If the lock has had a lot of use, such as that on a locker-room door where the shackle gets pulled down and encounters the tumblers while the combination is being dialed, the serrated front tumblers will become smoothed down, allowing easier

sensing of the tumblers. So, until you have become good at opening these locks, practice extensively on an old one. Let's try to open one:

OPENING A COMBINATION PADLOCK

STEP ONE

First, clear the tumblers by engaging all of them. This is done by turning the dial clockwise (sometimes these locks open more easily starting in the opposite direction) three to four times. Now bring your ear close to the lock and gently press the bottom back edge to the bony area just forward of your ear canal opening so that vibrations can be heard and felt. Slowly turn the dial in the opposite direction. As you turn, you will hear a very light click as each tumbler is picked up by the previous tumbler. This is the sound of the pickup pegs on each disk as they engage each other. Clear the tumblers again in a clockwise manner and proceed to step two.

STEP TWO

After you have cleared the tumblers, apply an upward pressure on the shackle of the padlock. Keeping your ear on the lock, try to hear the tumblers as they rub across the pawl; keep the dial rotating in a clockwise direction. You will hear two types of clicks, each with a subtle difference in pitch. The shallow, higher pitched clicks are the sound of the false gates on the first disk tumbler. Do not let them fool you-the real gates sound hollow and empty, almost nonexistent.

When you feel a greater than normal relief in the shackle once every full turn, this is the gate of the first tumbler (last number dialed). This tumbler is connected directly to the dial as mentioned earlier. Ignore that sound for now. When you have aligned the other two tumblers, the last tumbler's sound will be drowned out by the sound of the shackle popping open.

STEP THREE

While continuing in a clockwise direction with the dial, listen carefully for the slight hollow sound of either one of the first two tumblers. Note on the dial face where these sounds are by either memorizing them or writing them down. Make certain that you do not take note of the driving

tumbler (last number dialed). If you hear and feel only one hollow click (sounds like "dumpf"), chances are that the first number could be the same as the last one.

You should have two numbers now. Let us say one of them is 12 and the other is 26. Clear the tumblers again just to be safe and stop at the number 12. Go counterclockwise one complete turn from 12. Continue until there is another "dumpf" sound. After the complete turn pass 12, if you feel and hear a louder than normal sound of a tumbler rubbing on the pawl, the first tumbler is properly aligned and the second tumbler is taking the brunt of the force from the shackle-you are on the right track. When the second tumbler has aligned in this case, you will feel a definite resistance with the last turn of the dial going clockwise. The final turn will automatically open the shackle of the lock. If none of these symptoms are evident, try starting with the number of the combination, 26, in the same way.

STEP FOUR

If the lock still does not open, don't give up. Try searching for a different first number. Give it a good thirty- or forty-minute try. If you play with it long enough, it will eventually open. The more practice you have under your belt, the quicker you will be able to open these padlocks in the future.

Using a stethoscope to increase audibility of the clicks is not out of the question when working on disk tumbler locks, though I never use them for padlocks. A miniature wide-audio-range electronic stethoscope with a magnetic base for coupling a piezoelectric-type microphone is ideal for getting to know the tumblers better.

Filing your fingertips to increase sensitivity might not be such a good idea for beginners since their fingertips will not be accustomed to operating dials for a long period of time. With practice, you may develop calluses and need to file your fingertips. But I don't recommend it at first.

After some time you may find that in some cases you can whiz right through the combination of an unknown lock without looking at it and pop it open in seconds. It becomes second nature. I've done this on many occasions - something beyond my conscious control seems to line up the tumblers without my thinking about it.

Another type of disk tumbler padlock is the Sesame lock made by the Corbin Lock Co. Its unique design makes it more difficult to open than Master padlocks, but it can be opened. Let's take one of the three or four Wheel mechanisms, look at a cross section, and see how it works. The wheel has numbers from zero to nine. Attached to the wheel is a small cam. Both the wheel and cam turn on the shaft. Each wheel in this lock operates independently with its own cam and shaft. The locking dog is locked to the shackle. In this position the shackle cannot be opened. The locking dog operates with all three or four wheels. The locking dog is riding on the round edge of the cam. The spring is pushing up on the cam. The locking dog cannot move up because it is resting on the round part of the cam. When the wheel is turned to the proper combination number, the locking dog rests on the flat of the cam. The spring can then raise the locking dog to release the shackle, and this opens the lock.

TIPS FOR SUCCESS

You will undoubtedly encounter a pin tumbler lock in which there will be a pin or two that is keyed too low (the shear line of the pin is too high). In this case the lock is difficult to open because the breaking point of a long bottom pin doesn't allow room in the keyway for the pick to manipulate the other pins. Your success in opening "tight" locks will depend on the skill you have developed with your tension wrench. Sometimes it helps to play with the tension wrench. Try bouncing it left and right slightly while picking, allowing some of the tumblers to drop occasionally. You may also try picking the front tumblers first or picking at random on these locks. You can tell if you have a lock that is keyed like this because your pick may get jammed during the picking process.

After you have opened a cylinder and unlocked a lock, be sure to return it to the locked position. You will hear the tumblers click into place when this happens. Otherwise it may be difficult to unlock it with its key because the bottom pins cannot "float" like they normally would.

To tell whether or not the cylinder should go clockwise or counterclockwise when picking a tumbler lock, there is an easy rule to follow. If the tumblers (pin or wafer) will not break, or stay broken, you are going in the wrong direction with the tension wrench. There will be little or no progress with the cylinder, and few, if any, "clicks."

Some keyways are cut at an angle (Yale, Dexter, and Schlage, for example) so you want to be sure that you tilt your pick to follow that angle while picking or your pick will get hung up. A slight twist of the wrist will compensate for this problem.

Should your fingers become tired while picking a lock, lay down your tools and shake your hands and fingers to relieve any tension. After some time the muscles in your hands will become accustomed to such activity. Practice and persistence will tone your hands and senses to the point where you will be able to pop open a cylinder in three to five seconds (that's seconds) in total darkness. The combination of touch and sound lets you know almost a split second before you open the lock that you have succeeded.

If the lock is a well-machined one, the cylinder will feel tight and you will need a little firmer hand on the tension wrench. While picking, if any one of the pins at any time feels firm or difficult to move, chances are it's aligned. If it feels springy, it is not.

Use the shaft of the pick if you have to when working the frontal pin of a pin tumbler lock. This may save you the trouble of aligning the tip of the pick on the front pin where there is little or no support for the pick. All of the other pins allow the pick to be supported by the inside wall of the keyway.

Master keyed pin tumbler locks are generally easier to pick open because they have more than one shear line or breaking point in the pins. Master keying allows a group of locks to be controlled by a master key holder while the individual locks in that group are controlled by individual keys. Hotels and apartment complexes are usually master keyed.

There is a simple technique to open pin and wafer tumbler locks. Simply drill through the shear lines of the tumblers. This point is located just above the center of the keyway on the face of the cylinder. By doing this, though, you obviously ruin the lock and make a lot of racket. If the lock is a Medeco or some other high-security - lock, you risk damage of one hundred dollars or more, so be sure you know the value of the situation before you decide to rape the lock. Use a center punch to start a reliable hole on the cylinder face and use a one-quarter inch drill bit with a variable speed drill. With a large screwdriver, turn it to unlock. The cylinder

will be difficult to turn because you may be shearing the tumbler springs that have fallen down past the cylinder's shear line.

Dead bolt locks are those mounted on a door above the knob. All dead bolt locks unlock counterclockwise with left-hand doors and clockwise with righthand doors. If you have trouble remembering this, just remember that the bolt of the lock has to go in the opposite direction of the doorjam.

Dead bolt locks are just as easy to pick open as knob locks are. They both have cylinders that can be picked open. The main difference is that dead bolts cannot be opened by sliding a plastic or metal card through to the bolt so as to work it back. In other words, they are not spring loaded.

That's why they are called dead bolts. Most knob locks now have guards in front of the bolts to deter opening with cards.

Kwik-sets, Weisers, and some of the less-expensive knob locks may open in either direction. Schlage and Corbin, along with more sophisticated locks, can open only in one direction. Auto locks will open either way. Another method of picking pin tumbler locks is with a pick gun. As the pick snaps up, it hits the bottom pin. This bounces the top pin out of the cylinder and into the shell. As you apply light turning pressure with the tension wrench, the top pins are caught in the shell, the cylinder will turn. I've never used a pick gun, but they do work well for locksmiths who use them. They are cumbersome and expensive, and show some lack of professionalism.

(Note: If you don't care about professionalism and want to open 95% of all pin tumbler locks out there - and fast- buy this device. It is very awesome. I even recommend it over a Cobra Electronic lockpick. Trust me, I have both, and I feel the \$60 Lockaid pick gun blows away the \$350 Cobra).

SOME PRECAUTIONS

If you bought this book to learn how to pick locks in order to become a more efficient burglar, then there is not a whole lot I can say or do to stop you. But I must say this: the locks used in prisons are nearly impossible to pick even if you get or make the right tools. They are usually electrically controlled from an external station.

Do not carry lock picks on your person. If you get caught with them, you could get nailed for most any Professional job in town for the last seven years. If you must carry them, as in the case of rescue workers, etc., please consult your local authorities about details and ask about registering with them. As a former locksmith, I do not have that problem.

I advise that you do not teach your friends how to pick locks. The choice is yours, of course. You paid the price of this book and the knowledge is yours - be selfish with it. It is for your own protection as well. The fewer people who know you have this skill, the better. Getting blamed for something you didn't do is unfair and a hassle.

When you become proficient at picking locks, you may decide to get a job as a locksmith. But believe me, there is more to being a locksmith than being able to pick locks. You have to be a good carpenter as well as a fair mechanic. But you may want to approach the owner of a lock shop and ask if you could get on as an apprentice.

NOBODY'S PERFECT

There isn't a locking device on earth that cannot be opened with means other than its key or code. It's just that some are easier to open than others. Anything with a keyhole, dial, or access port is subject to being opened with alternate means, though some of the newer electronic and computer controlled security devices would be a nightmare even if you had extensive knowledge of electronics and electromagnetics. Some devices also use palm prints as a readout to allow entry.

On the mechanical side, there are locks that have normal pin tumblers, but they are situated in various places 360 degrees around the cylinder. Some locks use pin tumblers that not only have to be aligned vertically within the cylinder, but also have to "twist" or turn a certain number of degrees to allow the cylinder to open. This is because the pins' shear line is cut at an angle. These locks are made by Medeco.

I have witnessed only one Medeco lock being picked by a fellow locksmith. We both spent hours trying to pick it again, but it was futile. We estimated the chances of opening it again to be one out of 10,000. They are excellent security devices, but their price keeps them limited to areas prone to security problems such as isolated vending machines and for

government use. The only one I have been successful at opening (after an hour of picking) was one I drilled. By the way, they are easy to drill because the brass that's used is soft.

LEARNING TO TOUCH AND FEEL

Most of us know how to touch. We touch objects every day, and yet we do not truly feel them. It seems so commonplace that we forget that we are actually feeling while we touch.

Here is an exercise that will develop a delicate touch. Gently rub and massage your hands and fingers preferably with hand lotion. Do this for five minutes. Once the lotion has evaporated, shake your hands and fingers so that they flop loosely. Gently pull each finger to relax each joint.

Now with a piece of fine sandpaper, gently draw the tips of your fingers across it. Try to feel the texture of the grains on its surface. Relax your fingers, hands, forearms, shoulders, and chest. Take your time. Do this for several minutes.

After a few weeks of practice, you will be able to feel each individual grain of sand on the sandpaper. This allows you to feel the slightest sensation vibrate through your bones.

Try to remember to practice touching and feeling during your everyday experiences. Practice feeling wood, metal, and various other objects. Play with the feel of mechanical vibrations, even your television set. Try to sense the world around you as a source of information. This could and will open a whole new horizon of experience. After a while, you will be able to feel or sense the movement of the tumblers of a Sargeant and Greenleaf safe. My first safe opened in three minutes because of that technique that took me years to discover.

VISUALIZATION

If you respect the security of the lock and do not become over confident, you will never become disappointed if you fail to open it. You also increase your chances of opening the lock because you personally have nothing to gain or lose by opening it. Give up trying to be an expert and just pick the lock.

With such an attitude, you may find the lock will usually pop right open. I never received a trophy for being the best lock picker in the state. My satisfaction is in knowing that I am never helpless in a lockout situation. The quality of your success is almost romantic; it involves sensitivity and compassion in the face of curiosity as a means to help others.

Visualization and imagination are important to the lock picker. I've noticed that people who have the ability to visualize the internal parts of the lock that they are picking seldom fail to open it in moments. Anyone can learn to do this by simply remembering to do it while picking a lock. Since sight, sound, and touch are involved with the process, visualization is very easy to do. Try to keep all of your attention on the lock during the picking process. This will help you to learn how to use heightened sensitivity for picking locks.

So in that respect, an unopened lock is like a new and unexplored lover. You imagine all of the qualities of an attractive person whom you've just met and apply that feeling to the lock that you are picking. Use visualization. It will help immensely.

ILLUSTRATIONS

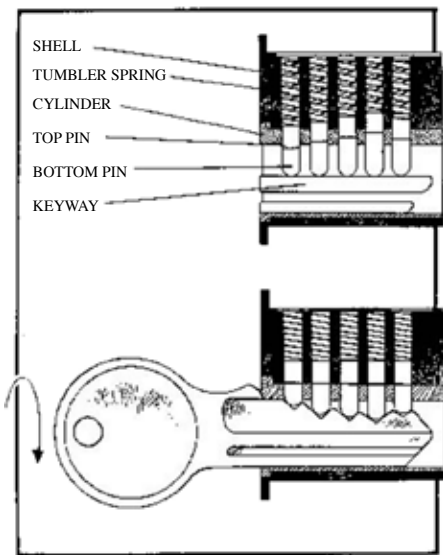

Figure 1. The pin tumbler lock, cutaway view.

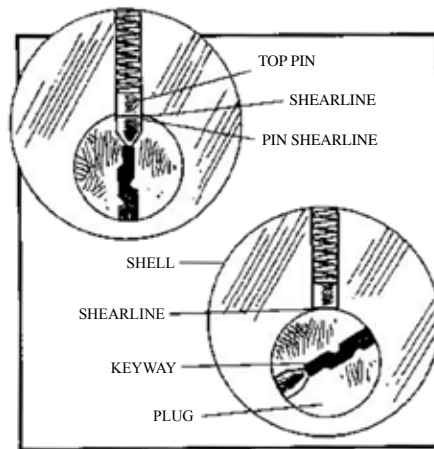

Figure 2. The pin tumbler lock, front view.

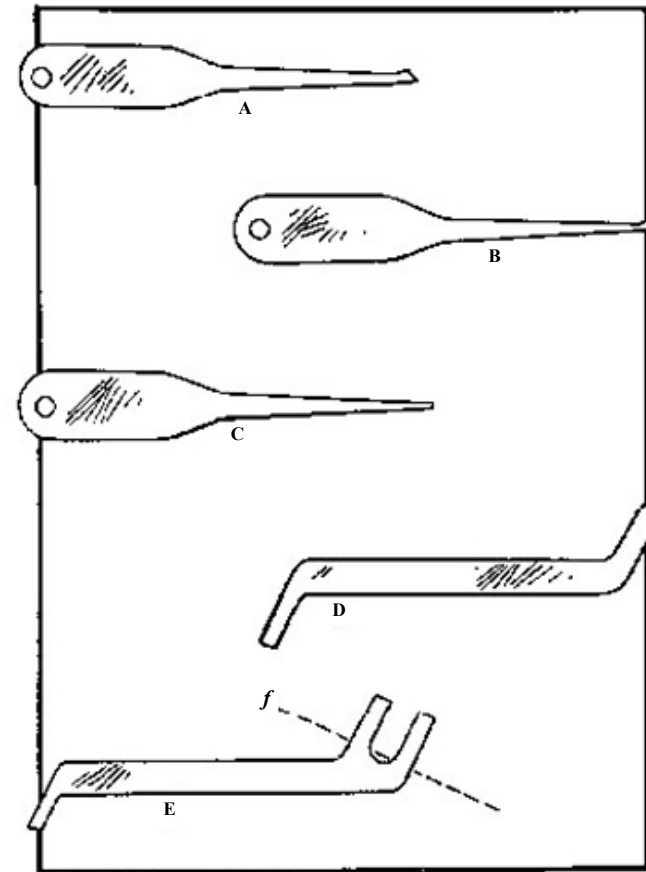

Figure 3. A. a diamond pick B. a small diamond pick C. a tubular cylinder lock pick D. a tension wrench, used with the diamond picks E. a tension wrench-intended for double-wafer cylinder locks and tubular locks.

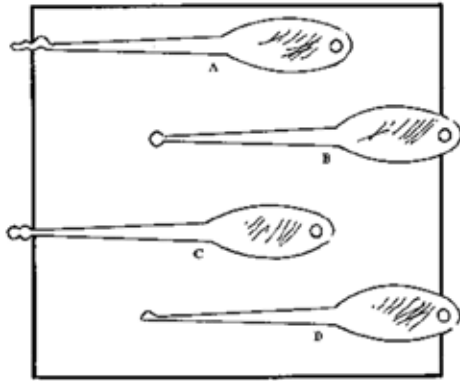

Figure 4. A. a rake pick B. a ball pick C. a double ball pick D. a diamond pick.

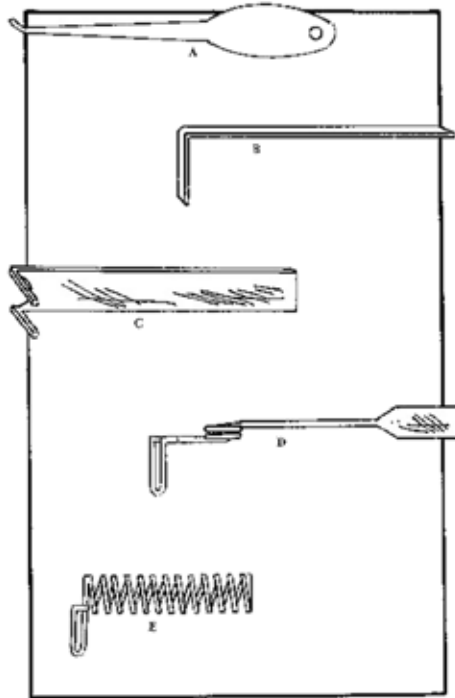

Figure 5. A. a hook pick B. a pin and wafer lock tension wrench C. a double-wafer tension wrench D. a Feather Touch tension wrench E. a homemade Feather Touch tension wrench,

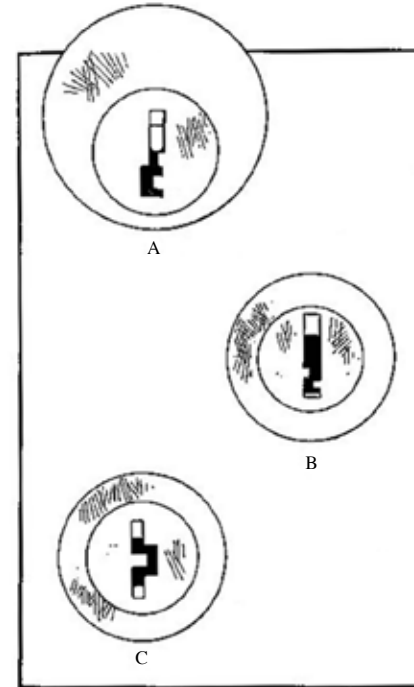

Figure 6. A. a pin tumbler lock B. a wafer tumbler lock C. a double-wafer tumbler lock.

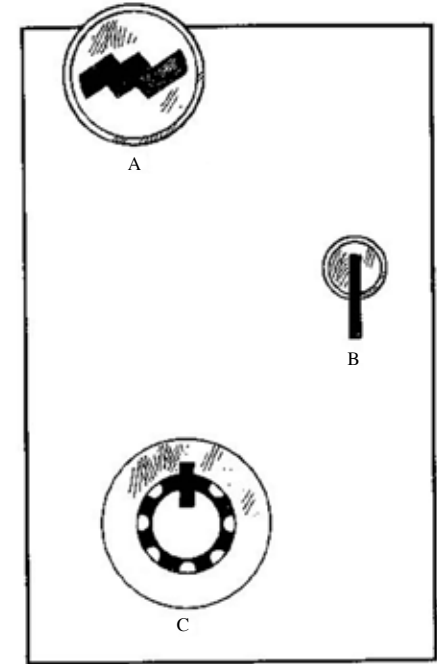

Figure 7. A. a warded lock B. a lever lock C. a tubular cylinder lock.

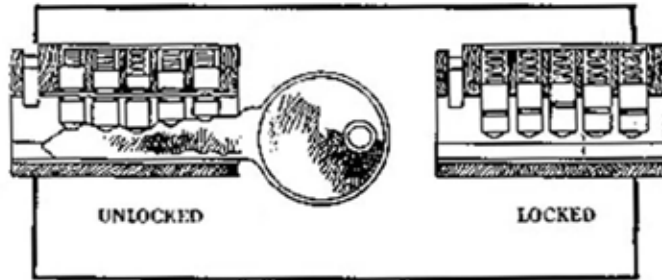

Figure 8. A pin tumbler lock.

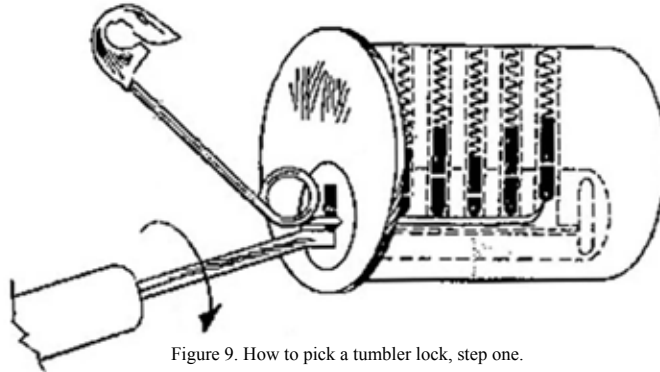

Figure 9. How to pick a tumbler lock, step one.

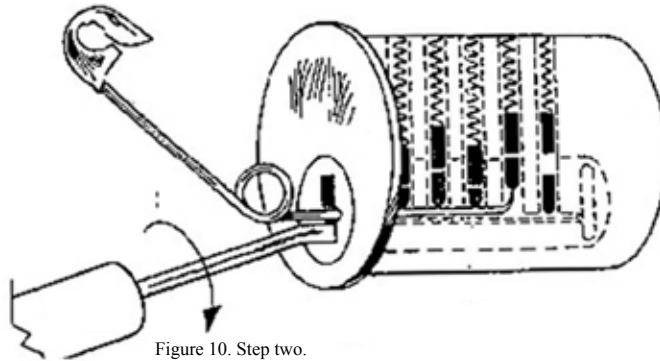

Figure 10. Step two.

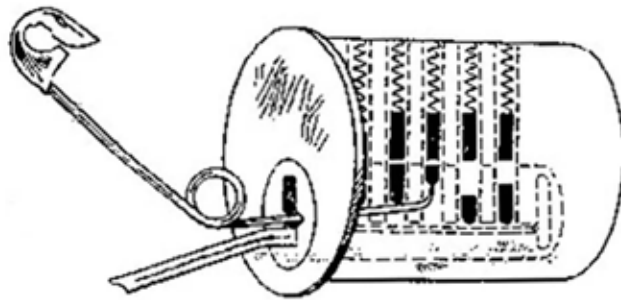

Figure 10. Step two.

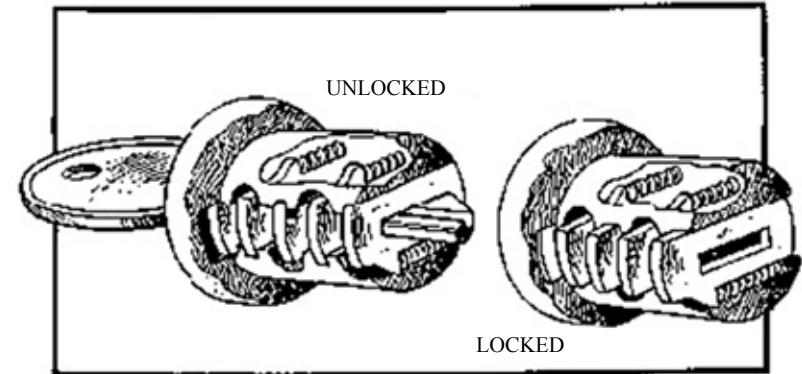

Figure 12. A wafer tumbler lock.

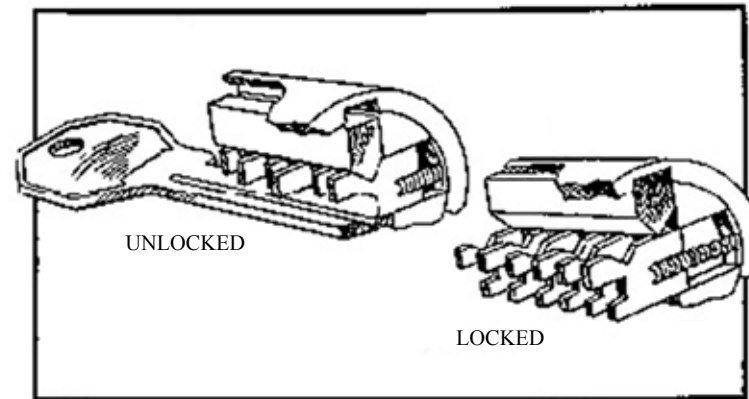

Figure 13. A side bar lock.

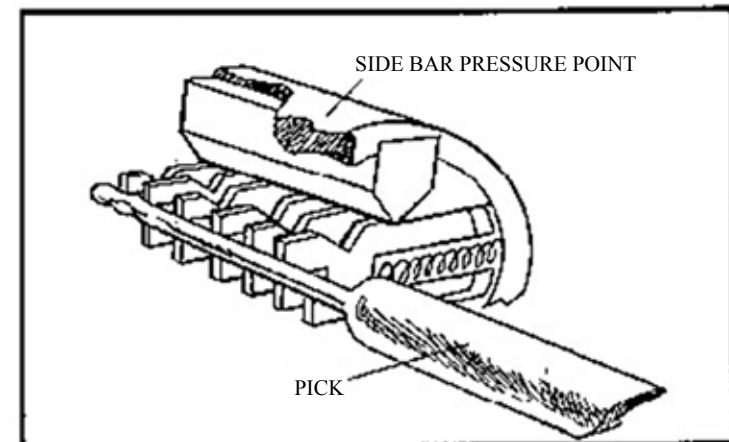

Figure 14. The rake pick inserted in the side bar lock.

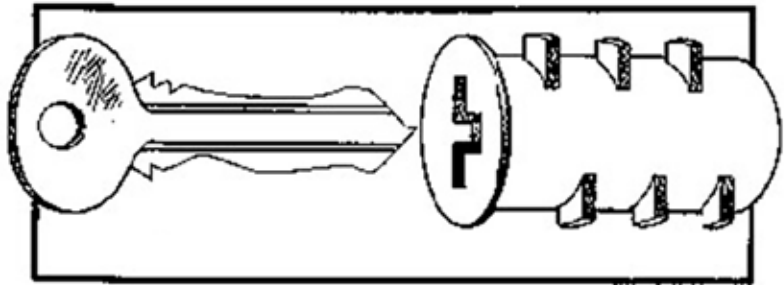

Figure 16. A double-wafer lock.

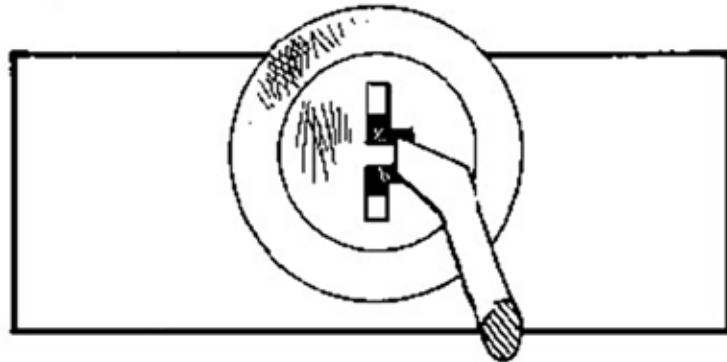

Figure 16. Inserting a tension wrench in a double-wafer lock.

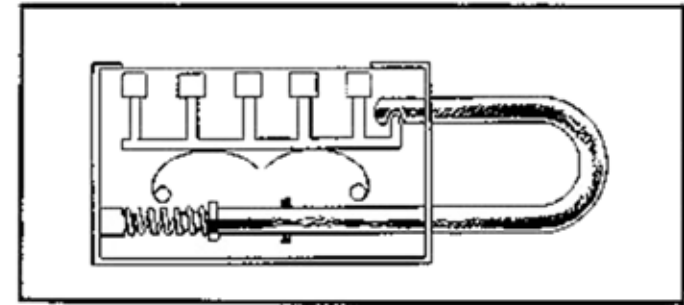

Figure 17. The inner mechanism of a magnetic lock is rather simple.

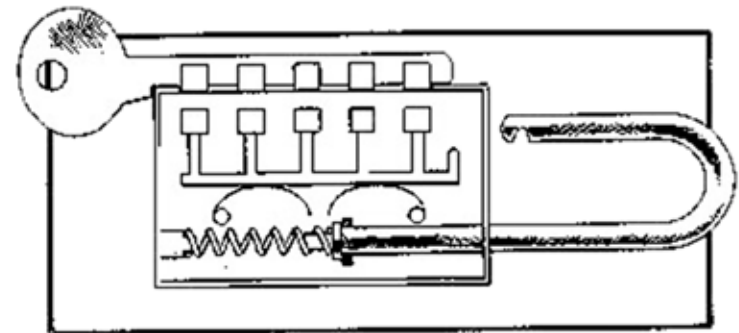

Figure 18. The magnetic key has the same sequence of magnets as the lock.

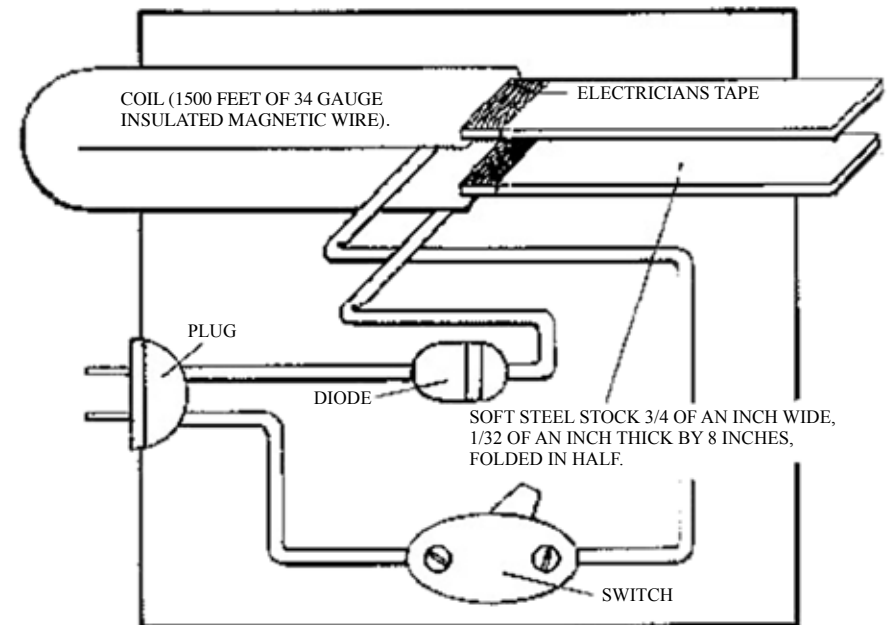

Figure 19. The magnetic pick is easy to construct.

Distribution Copyright 1987, 1991 Theodore T. Tool. All rights reserved. Permission to reproduce this document on a non-profit basis is granted provided that this copyright and distribution notice is included in full. The information in this booklet is provided for educational purposes only.
August 1991 revision.

claire fontaine

**some instructions
for the sharing
of private property**

**Edition limited to 250 numbered copies.
In addition to this book a limited edition multiple by the artist
is available from onestar press.**

Printed and bound in France

2011

**onestar press
49, rue Albert
75013 Paris France
info@onestarpress.com
www.onestarpress.com**

/250

